

05-02-2002

Substitute Form PTO-1595  
Attorney Docket No.: 08139-001001

A



REC

102072125  
PATENTS ONLY

ET

MRD 5-1-02

Commissioner for Patents: Please record the attached original document(s) or copy(ies).

1. Name of conveying party(ies): Paul T. Kolen and Thomas D. Ford Additional name(s) attached? <input type="checkbox"/> Yes <input checked="" type="checkbox"/> No		2. Name and address of receiving party(ies): Shannon Cool Limited Bay 21, Shannon Industrial Estate Shannon, County Clare Ireland  Additional names/addresses attached? <input type="checkbox"/> Yes <input checked="" type="checkbox"/> No	
3. Nature of conveyance: <input checked="" type="checkbox"/> Assignment <input type="checkbox"/> Merger <input type="checkbox"/> Security Agreement <input type="checkbox"/> Change of Name <input type="checkbox"/> Other: Execution Date: 02/10/1995 (Both)			
4. Application number(s) or patent number(s): If this document is being filed with a new application, the execution date of the application is: A. Patent Application No(s).: B. Patent No(s).: 5,865,841 Additional numbers attached? <input type="checkbox"/> Yes <input checked="" type="checkbox"/> No			
5. Name/address of party to whom correspondence concerning document should be mailed: TIMOTHY A. FRENCH Fish & Richardson P.C. 225 Franklin Street Boston, Massachusetts 02110-2804		6. Total number of applications/patents involved: 1 7. Total fee (37 CFR §3.41): \$40 <input type="checkbox"/> Enclosed <input checked="" type="checkbox"/> Authorized to charge Deposit Account. 8. Deposit Account No.: 06-1050 Please apply any additional charges, or any credits, to our Deposit Account No. 06-1050.	
DO NOT USE THIS SPACE			
9. Statement and Signature: <i>To the best of my knowledge and belief, the foregoing information is true and correct and any attached copy is a true copy of the original document.</i>			
Timothy A. French Reg. No. 30,175 Name of Person Signing		 Signature	April 26, 2002 Date
Total number of pages including coversheet, attachments and document: 30			

20427407.doc

05/02/2002 GT0N11 00000118 061050 5865841

01 FC:581 40.00 CH  
02 FC:584 120.00 CH

PATENT  
REEL: 012641 FRAME: 0131

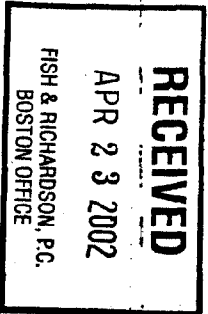

DEED OF ASSIGNMENT dated the 23<sup>rd</sup> day of February 1995

BETWEEN

DR. PAUL THEODORE KOLEN of 139 Fourth Street, Encinitas, California, 92024, USA and MR. THOMAS D. FORD of 10405 Orozco Street, San Diego, California, 92124, USA (hereinafter collectively called "the Assignors") of the one part

AND

SHANNON COOL LIMITED having its registered office at Bay 21, Shannon Industrial Estate, Shannon, County Clare, Ireland (hereinafter called "the Assignee") of the other part

WHEREAS

- A. The Assignors are the beneficial owners of the invention described in the Schedule hereto (hereinafter called "the Invention").
- B. The Assignors agree to assign all their rights, entitlement and beneficial interests in the Invention to the Assignee for the consideration hereinafter mentioned.

NOW THIS AGREEMENT WITNESSETH that the Assignors, as beneficial owners, and in consideration of the payment of the the sum of US\$1.00 by the Assignee to the Assignors (receipt of which the Assignors doth hereby acknowledge), doth hereby assign absolutely to the Assignee free from encumbrances all their right title and interest in and to the Invention together with all rights and powers arising or accruing therefrom including the right to sue for damages and other remedies in respect of any infringement of the rights to the Invention heretofore held by the Assignors AND the right to apply for and prosecute and obtain patent or similar protection throughout the world in respect of the Invention including the right to claim priority therefrom to intent that the grant of any such patents or similar protections will be in the name of and vest in the Assignee.

The Assignors warrant to the Assignee that the Invention has not been disclosed by the Assignee to the public or any portion thereof in any part of the world.

The Assignors further covenant that, at the request and cost of the Assignee, they will at all times hereafter do all such acts and execute all such documents as may reasonably be necessary or desirable both to secure the vesting in the Assignee of all rights assigned to the Assignee hereunder and to assist in the resolution of any questions concerning the Invention or any patents or patent applications made by the Assignee in respect of the Invention.

**SCHEDULE**

A Cold Therapy Apparatus the specification for which is more particularly described in the document annexed hereto together with all derivative designs and technologies incorporated in or arising from the invention or any part of it.

IN WITNESS WHEREOF the parties hereto have set their hands and affixed their seals the day and year first herein WRITTEN.

SIGNED SEALED and DELIVERED  
by the ASSIGNORS  
in the presence of:-

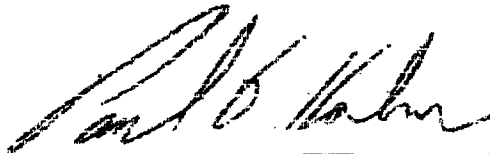

DOCTOR PAUL T KOLEN



MR. THOMAS D. FORD

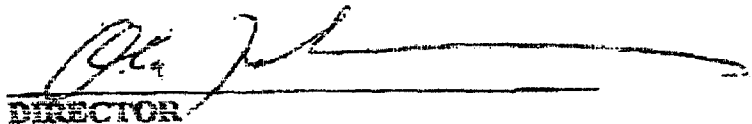

PRESENT when the Common Seal  
of the ASSIGNEE  
was affixed hereto:-

  
DIRECTOR  
DIRECTOR/SECRETARY

**SCHEDULE TO DEED OF ASSIGNMENT (1995)**

**U.S. Patent**

<b>Patent No.</b>	<b>Date</b>	<b>Inventors</b>	<b>Title</b>
5,865,841	02/02/1999	Paul T. Kolen; Thomas D. Ford	Cold Therapy Apparatus

**Foreign Patent**

<b>Country</b>	<b>Patent No.</b>	<b>Date</b>	<b>Title</b>
Ireland	S66404	12/27/1995	Applying Thermal Therapy to Living Tissue

20426819.doc

**BACKGROUND OF THE INVENTION**

This invention relates to the application of cold or heat to affect heat transfer to or from the human or mammalian body. The necessity for such an application may arise in a wide range of circumstances. Most common are injuries, bruises, sprains, or other trauma to bone, muscle, ligaments, tendons, skin and other forms of mammalian tissue. The application of cold or cooling to reduce swelling, reduce pain and promote healing at the traumatized area of the human or mammalian body is often recommended. Similarly, the application of heat or heating to the human or mammalian body is used to warm up or "loosen-up" joint tissue such as ligaments or tendons prior to use to facilitate an increased range of motion prior to normal or strenuous physical activities.

Other circumstances in which the need for application of cold or heat therapy to the human or mammalian body may arise include post-surgical therapy to reduce pain and swelling and promote healing, as well as in orthopedic therapy, sports medicine therapy and rehabilitation programs and applications. Of particular importance are the areas of athletic injury and subsequent therapy, healing and rehabilitation in humans, and injury and subsequent therapy, healing and rehabilitation in thoroughbred race horses.

The most common method of achieving the desired cooling effect has been application of an ice bag to the desired therapy site. This method has several limitations. Ice bags can be cumbersome to apply, and in the case of animals, for example thoroughbred race horses, may be difficult to maintain on the therapy site.

5 Ice bags can apply uneven cooling to the therapy site, are often difficult to contour to the area of the mammalian body to be treated, and the intensity of cooling is difficult to control. Often the application is either too cold, or not cold enough. A

10 common ice bag has further limitations as well. As the ice melts, an ice bag may leak, causing inconvenience or more serious consequences. Finally, the static application of cold or cooling

15 can become uncomfortable and unpleasant, usually resulting in the subject prematurely terminating the application before the full beneficial affect can be achieved.

20 A number of variations have been proposed to improve upon the ice bag or pack, but none fully addressed all of its shortcomings. For example, some have been known to use a bag of frozen peas (or

25 other vegetables) as a substitute for an ice bag. The frozen peas allow more uniform cooling of the site, generally contour to the site better than a bag of ice cubes, and apply less severe cooling. Of course, this alternative has a number of drawbacks as

30 well. A bag of frozen peas has limited available cooling capacity, and as with any bag, contouring to a part of the mammalian body such as the human knee can be difficult or impossible, resulting in uneven cold application.

Other variations on the basic ice bag or ice pack include a wrap or strap-on device which holds the source of cooling on the therapy site. These devices generally are designed for use on specific locations on the human body, and generally contour better to the therapy site and are held in place by means of belts or straps. These devices also have several shortcomings, however. Certain types have built-in reservoirs to provide a source of cooling, such as containers of frozen water. These devices must be kept frozen until ready to use, and once their cooling capacity is expired, they must be re-frozen before they can be used again. The intensity of cooling with these wrap or strap-on devices is also difficult to control, and they are capable of applying only static cooling to the site. There are also generally cumbersome, as the source of thermal cooling must be located entirely within the device and held at or on the therapy site.

Also available are chemical cold-packs comprised of two or more chemical substances stored separately in a flexible packet. When needed, the packet is manipulated, causing an internal seal to break and the chemical substances to mix. The substances, when mixed, have an endothermic reaction which causes the packet to cool. While these devices are useful in remote sites and in certain emergency situations, they afford little advantage over the ordinary ice bag. Furthermore, they can generally be used only one time, are of limited cooling capacity or duration,

operate at one non adjustable temperature, and are prohibitively expensive for use in a regular cold therapy program.

5 More recently, a commercially available apparatus for accomplishing the desired cooling of the human knee has been developed which incorporates a cold reservoir consisting of a large cooler. The water within the cooler is circulated by means of a pump which circulates the cooled water from the cooler  
10 through a tube to a bladder and back through a tube to the cooler. The bladder is applied to the therapy site and held in place by means of a wrap or strap device. This apparatus has many advantages over an ice pack or ice wrap. The cooler and source of  
15 cooling, generally ice, is held in a container separate from the therapy site. In this type of device, the rate of cooling is adjusted by increasing or decreasing the flow resistance by using a manually operated flow restriction valve or electrically  
20 setting the pump speed to a predetermined fixed value.

This apparatus also has several shortcomings. The device is  
25 incapable of supplying a measured and controlled cooling temperature to the therapy site, and is incapable of providing tactile stimulation to the therapy site. The device is also cumbersome in that the pump used to circulate the cooling fluid  
30 must be manually submerged in the cooler, and there is an ever-present danger of electrical shock due to the proximity of the electrical power cord and the circulating water.



The most common method for achieving the desired heating effect has been through the application of a hot water bottle or steamed towels to an injury site. As with similar cold therapy modalities, this form of heat therapy suffers from the same  
5 shortcomings in terms of ease of application and temperature regulation due to a lack of any temperature control mechanism at the injury site.

DESCRIPTION OF THE PRIOR ART

Heretofore, a number of devices and systems have been employed to impose cold with or without pressure on parts of the human or mammalian body. Miller (US Patent No. 2,531,074 of November 21, 1950) discloses an appliance for a dry massage of a therapy site by water of controlled temperature in a sequence at alternatively high and low pressures applied to a multitude of adjacent chambers of flexible wall material and suggests that the water can be either heated or cooled.

5

Chessey (US Patent No. 2,726,658 of December 13, 1955) discloses a system, including a coolant control and supply unit, and a liquid-impervious appliance receiving the coolant and applied as a pad to a body portion of an animal, including a mechanical refrigeration system thermostatically controlled by the temperature of the coolant which is pumped through the appliance.

10

15

Grossan (US Patent No. 3,993,053 of August 5, 1975) discloses a massaging system including a flexible pad having fixed to one face a set of elastic tubing coils forming part of a recirculating hydraulic system, including a pump for creating pulsating fluid flow, and suggests that the pressure and temperature of the circulating liquid may be controlled by the operator.

20

25

Copeland, et al. (US Patent No. 4,149,529 of September 16, 1977) discloses a portable apparatus for controllably cooling and variably applying pressure to a portion of a mammalian body including a liquid supply, control unit, means to circulate the liquid and heat exchanger in the fluid reservoir mounted in a supply unit of sufficient size to support the weight of a human and receive a human limb such that the reservoir may be employed as a whirlpool bath.

Although all the devices described above may be functional and presumably operable, there is a need for an improved apparatus for applying cold or heat to a human or mammalian body which is small enough to be easily transported and used in a wide variety of locations, adaptable to many different mammalian body forms and potential therapy sites, capable of providing controlled temperature therapy at a preset temperature or by a pre-programmed temperature profile, capable of monitoring the therapy temperature directly at the therapy site, and capable of providing tactile stimulation to the therapy site to alleviate the problems of static cooling and enhance the beneficial effects of the cooling therapy. The present invention fulfills these needs, and further provides related advantages.

### SUMMARY OF THE INVENTION

The present invention provides an easily transportable apparatus for applying closed-loop temperature controlled cold or heat to a portion of the human or mammalian body. The apparatus comprises an insulated water reservoir within a sturdy housing, covered by a splash-proof lid, and is small enough is be easily situated in any convenient location for cold/heat therapy by the user. Within the reservoir housing but external to the reservoir is contained a self-priming fluid pump with a means of exchanging a measured portion of the re-circulation water with water from the reservoir to maintain the circulation water at a desired temperature. The pump is powered by a small mechanically integrated electric motor. Also contain in this area are the microprocessor-based temperature and pump/heat exchanger control electronics, and internal fluid tubing connections between the pump and the water reservoir, and between the pump and supply line connectors mounted on the housing. User controls and a temperature read-out display are also located on the reservoir housing.

The reservoir in the reservoir housing can accommodate crushed ice, ice cubes or a pre-formed freezable cold source, such as commonly used in portable coolers, and contains enough cooling capacity for generally all therapy applications. The reservoir may be easily recharged with additional ice if needed while therapy is continuing, and without the need for the subject to remove the bladder from the therapy site. For heat therapy, hot

water can be introduced into the reservoir or the reservoir fluid can be actively heated by an immersible heater to maintain a constant temperature for controlled heating applications.

5 The apparatus monitors the therapy temperature and produces an audible signal when the cold or heat source is exhausted and the apparatus is no longer able to maintain the desired therapy temperature within certain preset tolerances.

10 The fluid supply lines from the pumps are connected to self-sealing, "quick disconnect" connectors, allowing the user to quickly and conveniently attach and detach various bladder types  
15 for various therapy applications. The apparatus can also be adapted to support simultaneous use of multiple bladders fluidly connected in series for therapy at multiple sites, as in  
20 bilateral surgery applications. Connecting the bladder to the reservoir housing is a pair of fluid supply lines which are terminated at one end by the mating half of the "quick  
disconnect" connectors mounted in the reservoir housing.

25 The supply line pair is held together and encapsulated by a layer of insulating material, such as closed-cell polyurethane foam, making the entire tubing assembly water-tight, durable, flexible,  
30 and fully insulated to reduce the ambient heat load on the unit and enhance the comfort and ease of use of the therapy apparatus. The supply line assembly may be of various lengths to suit the particular therapy subject and application. The supply line

assembly may be permanently affixed to the bladder or attached by means of "quick-disconnect" connectors at its terminal end. Affixed within the supply line assembly is a pair of thermistors or other suitable temperature-sensing devices, one located in each of the pair of fluid supply lines at or near the quick disconnect mounted in the reservoir housing, the output of which is monitored by the control electronics to implement the closed-loop temperature control of the cold or heat therapy.

5

10

Various shapes and sizes of bladder are contemplated to accommodate the various therapy subjects, whether human or animal, and the various therapy sites of the mammalian body. All bladders will generally consist of two layers of flexible plastic or other material, completely sealed or welded at the edge or seam, and constructed to allow generous expansion and contraction in response to the varying pressure imposed by the pumps when applying tactile stimulation, and to ensure even distribution of circulation water or other fluid and the subsequent cooling/heating effect on the therapy site.

15

20

25

The bladder is generally held within a mating strap or wrap, depending upon the therapy subject and site. The strap or wrap may be a fabric or rubber type material, such as neoprene rubber, which is secured to the therapy site by means of belts, straps, "Velcro" fasteners. The strap or wrap, when fastened properly, holds the bladder firmly and evenly against the therapy site, while allowing expansion and contraction in response to the

30

pressure fluctuations created by the pump when applying tactile stimulation.

5 The apparatus maintains temperature control at the therapy site  
by a controlled dynamic mixing of cold/hot water from the  
reservoir with the re-circulation water returning from the  
bladder within the heat exchanger. By using the real-time  
10 temperature information generated by the temperature sensing  
devices, the microprocessor controls the rate of reservoir/re-  
circulation fluid mixing within the heat exchanger. This  
maintains the circulation water temperature, and thus the injury  
15 site bladder temperature. To ensure even temperature distribution  
at the therapy site or sites, particularly when multiple bladders  
are used in series, maximum flow rates and delivery pressure is  
maintained to minimize the difference between outgoing and  
20 returning water temperatures regardless of the heat load. To  
achieve tactile stimulation at the desired therapy temperature,  
the pump is periodically turned off for a brief interval to allow  
the pressure within the bladder to return to zero before turning  
25 the pump back on. This action causes the bladder to undergo a  
deflation/inflation cycle which in turn causes a tactile  
stimulation in the tissue directly in contact with the bladder.  
30 The microprocessor-based control electronics and associated  
operating program operate the pump accordingly to provide maximum  
flow of circulation fluid and impose periodic pressure variations  
on the bladder such that the desired temperature control and  
tactile stimulation are provided at the therapy site.





**BRIEF DESCRIPTION OF THE DRAWINGS**

5 Figure 1 is a schematic view of the apparatus as typically used by a human subject when applying cold therapy to the knee joint.

10 Figure 2 is a perspective view of the reservoir housing with portions removed or broken away to reveal internal structure.

15 Figure 3 is a schematic view of the insulated supply lines and bladder showing the internal structure of the bladder.

20 Figure 4 is a cross-sectional view of a bladder.

DETAILED DESCRIPTION OF THE PREFERRED EMBODIMENT

Referring initially to Figure 2, there is shown the reservoir housing 4 which includes a protective outer case 2, and inner ice reservoir 19 which is formed within the outer case 2 and open at the top, but otherwise leak-proof. The walls of the reservoir 19 are spaced within and apart from the walls of the outer case 2, the internal space thus formed around the inner reservoir 19 is filled with a thermal insulation 18. The bottom wall 3 of the reservoir 19 is also covered with thermal insulation 18, thus insulating the reservoir 19. The reservoir 19 is covered during operation of the apparatus using a lid 5 which is also thermally insulated and incorporates a seal which fits snugly in the opening of the reservoir 19 to prevent leakage caused by splashing during movement of the apparatus.

Within the space adjacent to the reservoir 19 and within the outer case 2 are mounted the pump/heat exchanger 13, electric motor 9, microprocessor-based control electronics 7. pressurized water from the pump/heat exchanger 13 is supplied to the outlet quick disconnect 11 with the return water routed to the air/water separator 15 via the return quick disconnect 12 through return tube 1. To maintain a closed system, air from the priming valve 14 is vented back to the reservoir 19 via vent tube 17, with air vented from the air/water separator 15 via vent tube 16. Closed loop control is affected by two thermistors 20 placed in the supply tube to the outlet quick disconnect 11.

Electrical power is supplied from a conventional AC wall outlet through power connector 10 and power leads connecting to the switching power supply electronics 8.

5 Mounted on the reservoir housing 4 are user-operated display/control electronics 6 with push-button controls for user input and a digital display for setting and monitoring therapy temperature and time.

10 Referring to Figure 3, the bladder supply line assembly 40 is attached to the reservoir housing 4 by the mating halves of the "quick-disconnect" supply line connectors 21 and 22, connecting a pair of flexible supply tubes 41 and 42 to the internal fluid supply tubes via quick disconnects 11 and 12. The flexible supply tubes 41 and 42 are encased in thermal insulation 43 which reduces ambient heat loads and provides a comfortable means of managing the supply line assembly 40 on the therapy subject. Various lengths for the supply line assembly 40 are contemplated depending upon the particular therapy subject and application.

25 The supply line assembly 40 may be permanently affixed to the bladder 60 or attached by means of additional "quick-disconnect" supply line connectors 48 and 49.

30 Referring to Figure 3, the bladder 60 may be permanently affixed to the supply line assembly 40 or attached by means of the mating halves of additional "quick-disconnect" supply line connectors 38

and 39. Various bladder shapes and sizes are contemplated for application on specific therapy sites, such as the human knee, ankle, or elbow, to sufficiently surround the therapy site to achieve optimal cold therapy results. The general structure of the bladder 60 is preferably two layers of flexible, weldable polymer or other suitable material 61, which are heat-welded or otherwise sealed completely around the outer seam of the bladder 62. Bladder supply tubes 63 and 64 are attached to the bladder 60 by means of a leak-proof seal 65. The bladder 60 may incorporate one or more internal seams 66 or internal walls (not shown), the function of which is to direct the flow of cooling fluid from the bladder supply tubes 63 and 64 uniformly through the bladder 60, and provide control over expansion of the bladder 60 in response to the higher periodic pressure imposed during tactile stimulation of the therapy site as illustrated in figure 4.

Referring to Figure 1, the bladder 60 is held on the therapy site preferably by means of a wrap 70 made of neoprene rubber or other suitable insulating, flexible material, which is shaped to hold the bladder 60 snugly on the therapy site but allow flexibility for expansion and contraction of the bladder 60 during tactile stimulation of the therapy site. The wrap is held in place preferably by means of "Velcro" fasteners which are attached or sewn onto the wrap 70 such that the wrap 70 can be adjusted by the particular user to fit snugly and comfortably.

The apparatus maintains therapy temperature control at the therapy site by pumping circulation water at a precisely determined temperature from the pump/heat exchanger 13 through the bladder 60 to achieve the desired preset therapy temperature or preprogrammed therapy temperature-time profile, as monitored by the thermistors 20. The reservoir 19, pump/heat exchanger 13, supply tubes 41 and 42, and bladder 60 form a fluid circuit in which fluid may flow in either direction. Net flow through the bladder 60 is achieved by creating a pressurized output flow via the pump/heat exchanger 13 with the spent water returning from the bladder 60 to the air/water separator and ultimately to the inlet side of the pump/heat exchanger 13. The pump/heat exchanger 13, under microprocessor control, continuously displaces a precise amount of re-circulation water with water from the constant temperature reservoir to precisely maintain the temperature of the circulation water exiting the pump/heat exchanger 13. The displaced re-circulation water is returned to the reservoir via the air/water separator 15 to maintain a constant volume in the circulation system. To ensure a uniform temperature distribution at the therapy site or sites, particularly when multiple bladders are used in series in post-bilateral surgery therapy, maximum flow rate and pressure through the circulation system is maintained.

To achieve tactile stimulation when this mode of operation is selected by the user, while maintaining the preset or preprogrammed therapy temperature, the pump/heat exchanger 13 is

periodically turned off for preprogrammed intervals to periodically allow the pressure in the bladder 60 to be cycled between zero and maximum. This imposed periodic pressure variation on the bladder 60 will provide tactile stimulation at the therapy site while maintaining the desired therapy temperature through the resulting deflation/inflation cycles in response to the pressure variations.

The control electronics 7 incorporate sufficient non-volatile electronic memory to allow storage, recall and implementation of a plurality of preprogrammed or user-programmed therapy temperature-time profiles, in addition to the operating program of the apparatus. In addition to the plurality of preprogrammed therapy temperature-time profiles contemplated to be provided with the apparatus, user-programming may be accomplished through the keys incorporated into the control/display electronics 6.

The present invention provides an easily transportable cold therapy apparatus providing closed-loop therapy temperature control and tactile stimulation of the therapy site which may be used by human and mammalian subjects and employed on various therapy sites. Other embodiments within the scope of the invention are feasible. For example, a device with dual pumps capable of bi-directional flow closed-loop temperature control and increased tactile stimulation is feasible. A dual pump device could implement closed-loop temperature control using analog control electronics in the form of a solid state thermostat with

the therapy site temperature selected with a mechanically operated device, such as a potentiometer in conjunction with a temperature read-out device. Increased tactile stimulation for a dual pump device could be achieved by engaging both pumps simultaneously, imposing momentary higher pressure on the bladder with no net fluid flow momentarily. Since many changes could be made in the above construction and many apparently widely different embodiments of this invention could be made without departure from the scope thereof, it is intended that all matter contained in the above description or shown in the accompanying drawings shall be interpreted as being illustrative only and not limiting.

- 20 -

CLAIMS:

1. A transportable cold/heat therapy apparatus for applying cold/heat therapy to one or more therapy sites  
5 on the human or mammalian body comprising:  
a means to select and set a constant therapy temperature;  
a means to program and store one or more therapy temperature-time profiles;  
10 a means to control the therapy temperature at a substantially constant value, or to follow with substantial accuracy a therapy temperature-time profile;  
a means to measure and monitor with substantial  
15 accuracy the therapy temperature applied at the therapy site or sites;  
a means to apply tactile stimulation at the therapy site or sites while controlling therapy temperature; and  
20 a means to warn the user whenever the apparatus lacks sufficient cooling or heating capacity to control the therapy temperature at a constant value, or according to a therapy temperature-time profile, within at preset temperature tolerance value.  
25
2. An apparatus as claimed in claim 1 wherein said means to program and store one or more therapy temperature-time profiles includes microprocessor-based control electronics and associated operating program,  
30 connected to user-operated push-button controls and a digital display, said push-button controls and said digital display enabling the user to manually select and visually confirm a therapy temperature-time profile, said control electronics and associated  
35 operating program capable of storing and retrieving the



therapy temperature-time profile and determining the  
time-varying therapy temperature specified in the  
therapy temperature-time profile in real time for  
purposes of implementing closed-loop therapy  
5 temperature control.

3. An apparatus as claimed in Claim 1 or 2 wherein  
said means to measure and monitor with substantial  
accuracy the therapy temperature applied at the therapy  
10 site or sites includes microprocessor-based control  
electronics and associated operating program and two  
thermistors connected to said control electronics, one  
said thermistor mounted in each of two supply tubes  
supplying circulating fluid to a bladder device, said  
15 control electronics and associated operating program  
monitoring the output of said thermistors and computing  
the actual circulation fluid temperature detected by  
said thermistors for purposes of implementing  
closed-loop therapy temperature control via the  
20 pump/heat exchanger.

4. An apparatus as claimed in any one of Claims 1-3  
wherein said means to apply tactile stimulation at the  
therapy site or sites includes an electric-powered  
25 fluid pump, said fluid pump connected to  
microprocessor-based control electronics and associated  
operating program, said fluid pump having its fluid  
input connected to a heat exchanger containing  
controlled temperature fluid and its fluid output  
30 connected by a fluid supply tube to a bladder device,  
and having the capability of pumping fluid from said  
heat exchanger to said bladder device when operated,  
said control electronics and associated operating  
program periodically modulates the bladder pressure for  
35 preprogrammed intervals, thereby periodically imposing

- 22 -

near zero pressure on said bladder device thus creating tactile stimulation through the inflation/deflation cycle.

5        5.        An apparatus as claimed in any one of Claims 1-4  
         wherein said means to warn the user whenever the  
         apparatus lacks sufficient cooling/heating capacity to  
         control the therapy temperature at a constant value, or  
         according to a therapy temperature-time profile, within  
10        a preset temperature tolerance value includes two  
         thermistors connected to microprocessor-based control  
         electronics and associated operating program, one said  
         thermistor mounted in each of two supply tubes  
         supplying controlled temperature fluid to a bladder  
15        device, said control electronics and associated  
         operating program monitoring the output of said  
         thermistors and producing an audible signal from a  
         sound-emitting device when the temperature detected by  
         said thermistors indicates that the cooling/heating  
20        capacity in said reservoir is insufficient for  
         maintenance of the closed-loop therapy temperature  
         control within the preset temperature tolerance value.

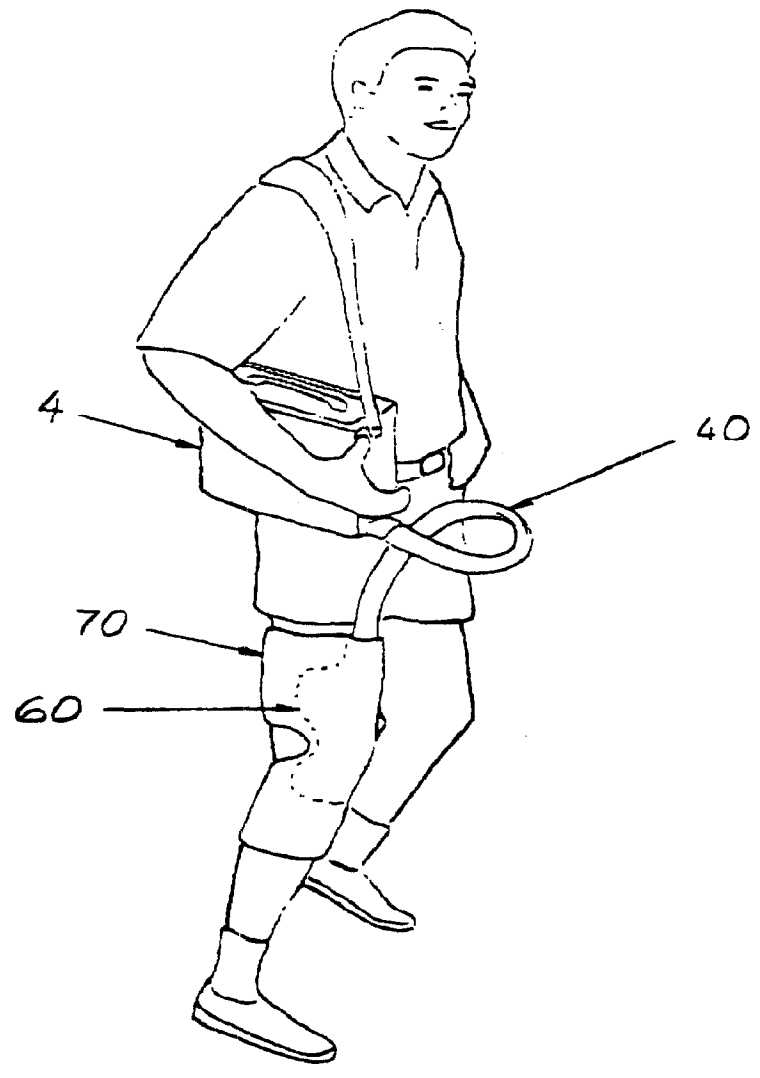

FIG. 1

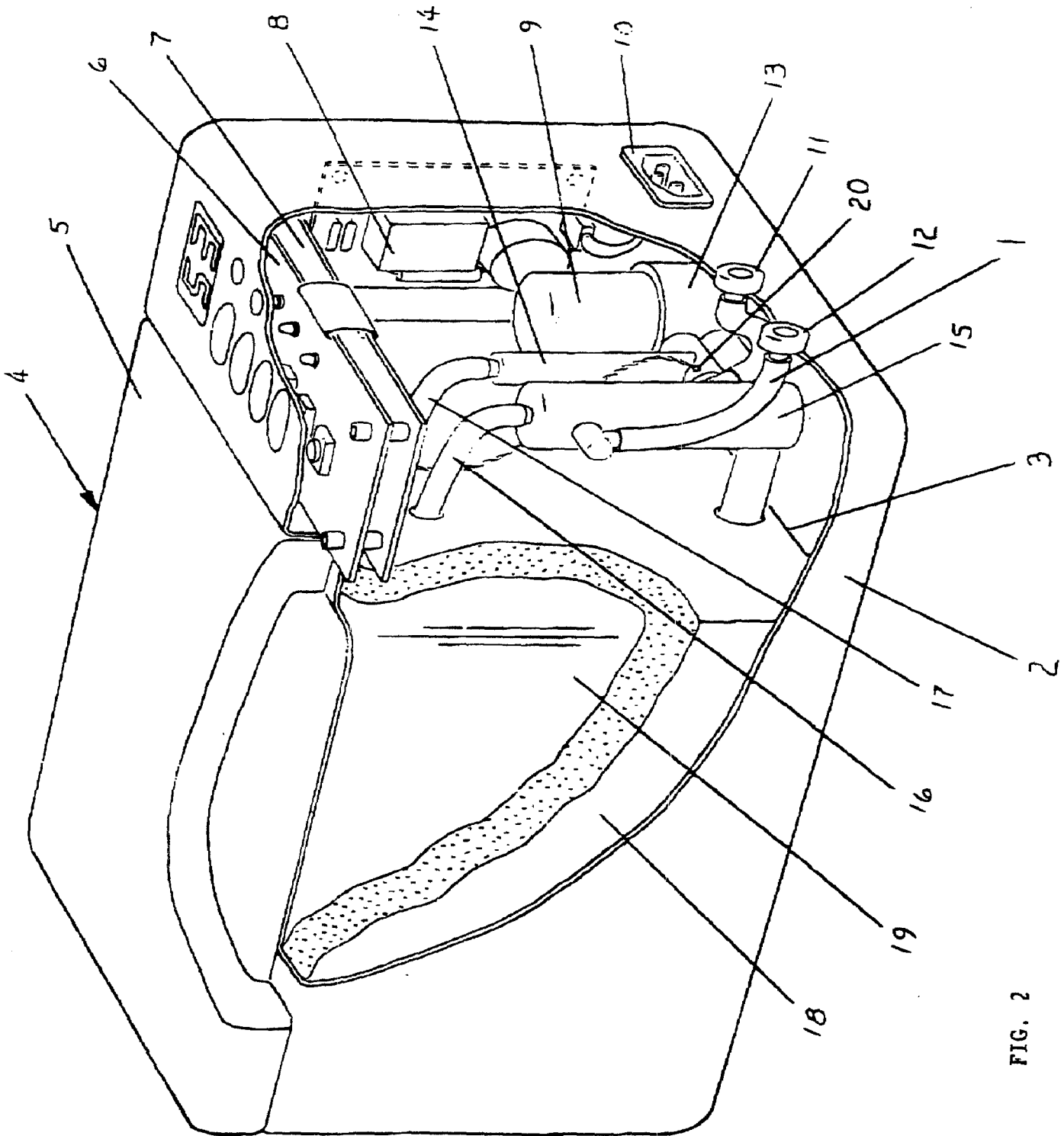

FIG. 2

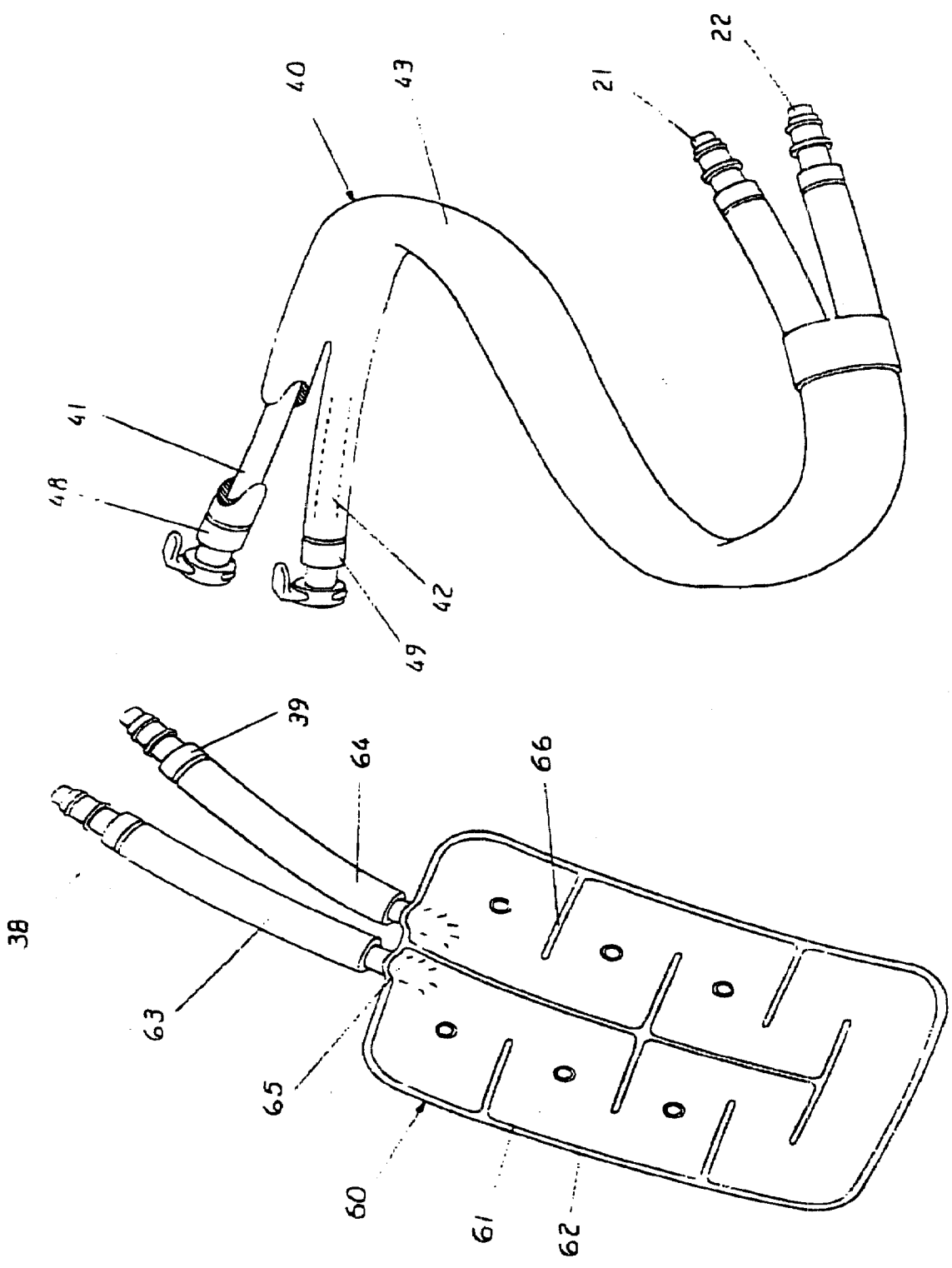
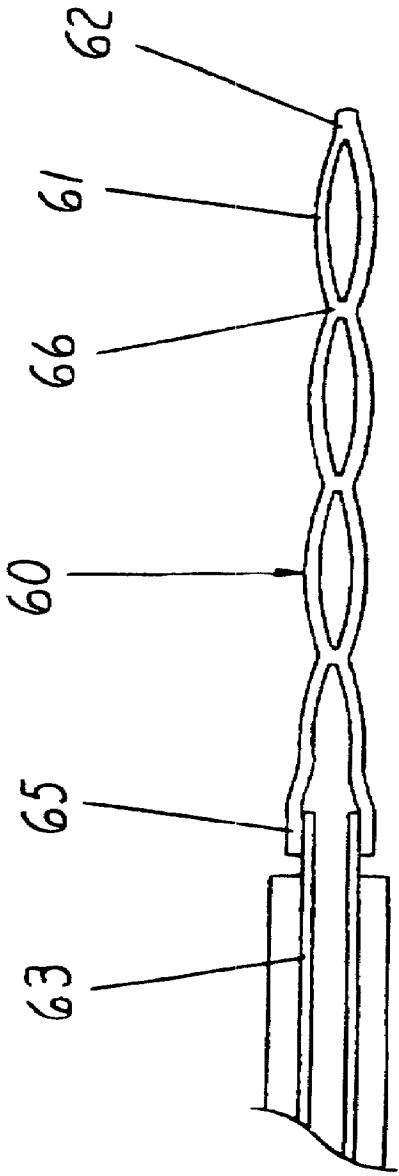
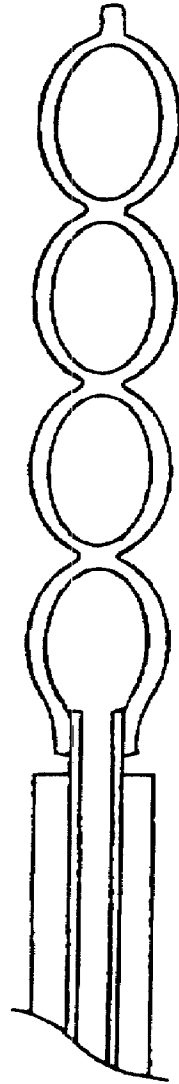

FIG. 3



DEFLATED BLADDER



INFLATED BLADDER

FIG. 4