

08-16-2006



103291620

OFFICE OF PUBLIC RECORDS

2006 AUG 14 PM 4:44

8/14/06

To the Director of the U.S. Patent and Trademark Office: Please record the attached documents or the new address(es) below

1. Name of conveying party(ies)

Chi Gon Chen

Additional name(s) of conveying party(ies) attached? Yes No

2. Name and address of receiving party(ies)

Name: International Development Corporation

Internal Address: _____

Street Address: 899 Henrietta Creek Road

City: Roanoke

State: Texas

Country: USA

Zip: 76244

Additional name(s) & address(es) attached? Yes No

3. Nature of conveyance/Execution Date(s):

Execution Date(s) May 23, 2006

- Assignment Merger
- Security Agreement Change of Name
- Joint Research Agreement
- Government Interest Assignment
- Executive Order 9424, Confirmatory License
- Other _____

4. Application or patent number(s):

This document is being filed together with a new application.

A. Patent Application No.(s)
29/256,649

B. Patent No.(s)

Additional numbers attached? Yes No

5. Name and address to whom correspondence concerning document should be mailed:

Name: David G. Moore

Internal Address: Suite 4400

Street Address: 901 Main St.

City: Dallas

State: Texas

Zip: 75202

Phone Number: 214-651-4300

Fax Number: 214-651-4330

Email Address: david.moore@strasburger.com

6. Total number of applications and patents involved: _____

7. Total fee (37 CFR 1.21(h) & 3.41) \$40

- Authorized to be charged by credit card
- Authorized to be charged to deposit account
- Enclosed
- None required (government interest not affecting title)

8. Payment Information

a. Credit Card Last 4 Numbers _____
Expiration Date _____

b. Deposit Account Number _____

Authorized User Name _____

9. Signature:

Signature

August 8, 2006

Date

08/15/2006 DBYRNE 00000002 29256649 David G. Moore

Name of Person Signing

Total number of pages including cover sheet, attachments, and documents:

8

Documents to be recorded (including cover sheet) should be faxed to (571) 273-0140, or mailed to:
Mail Stop Assignment Recordation Services, Director of the USPTO, P.O.Box 1450, Alexandria, V.A. 22313-1450

ASSIGNMENT

WHEREAS, I, **CHI GON CHEN**, ASSIGNOR, residing at Sha Xi Industrial, Jiang Gao Town, Bai Yun Interval, Guang Zhou, China, and citizen of the People's Republic of China, am the sole inventor of the invention entitled "**Solar Powered Insect Exterminator**," a drawing of which is attached hereto as Exhibit "A" and incorporated by reference as if fully set forth herein; and

WHEREAS, **INTERNATIONAL DEVELOPMENT CORPORATION d/b/a IDC**, a Texas corporation, ASSIGNEE, is desirous of obtaining my entire right, title, and interest in, to, and under the same invention and the said application:

NOW, THEREFORE, in consideration of the sum of Ten Dollars (\$10.00) to the said ASSIGNOR in hand paid, and for other good and valuable consideration, the receipt of which is hereby acknowledged, I, the said ASSIGNOR, have sold, assigned, transferred, and set over, and by these presents do hereby sell, assign, transfer, and set over, unto the said ASSIGNEE, its successors, legal representatives, and assigns, my entire right, title, and interest in, to, and under the said invention, and the said patent application, and all divisions, renewals, and continuations thereof, and all patents of the United States which may be granted thereon and all reissues thereof; and all applications for industrial property protection, including, without limitation, all applications for patents, utility models, and designs which may hereafter be filed for said invention in any country or countries foreign to the United States, together with the right to file such applications and the right to claim for the same the priority rights derived from said applications under the Patent Laws of the United States and the International

Convention for the Protection of Industrial Property, or any other international agreement or the domestic laws of the country in which any such applications are filed, as may be applicable; and all forms of industrial property protection, including, without limitation, patents, utility models, and design which may be granted for said invention in any country or countries foreign to the United States, and all extensions, renewals, and reissues thereof;

I FURTHER HEREBY authorize and request the Commissioner for Patents of the United States, and any official of any country or countries foreign to the United States, whose duty it is to issue patents or other evidence or forms of industrial property protection on applications as aforesaid, to issue the same to the said ASSIGNEE, its successors, legal representatives, and assigns, in accordance with the terms of this instrument;

I FURTHER HEREBY covenant that I have full right to convey my entire interest herein assigned and that I have not executed, and will not execute, any agreement in conflict herewith;

I FURTHER HEREBY convent and agree that I will communicate to the said ASSIGNEE, its successors, legal representatives, and assigns, any facts known to me respecting said invention, and testify in any legal proceeding, sign all lawful papers, execute all divisions, continuing and reissue applications, make all rightful oaths, and generally do everything possible to aid the said ASSIGNEE, its successors, legal representatives, and assigns, to obtain and enforce proper patent protection for said invention in all countries.

IN TESTIMONY WHEREOF, I hereunto set my hand and seal on the date indicated below.

DATED: May 23, 2005



CHI GON CHEN, Inventor and Assignor

THE STATE OF _____
COUNTY OF _____

§
§
§

BEFORE ME, the undersigned authority, on this day personally appeared CHI GON CHEN, known to me to be the person of that name, who signed the foregoing instrument and acknowledged the same to be his free act and deed.

GIVEN under my hand and seal of office this _____ day of May, 2005.

Notary Public, State of _____

EXHIBIT "A"

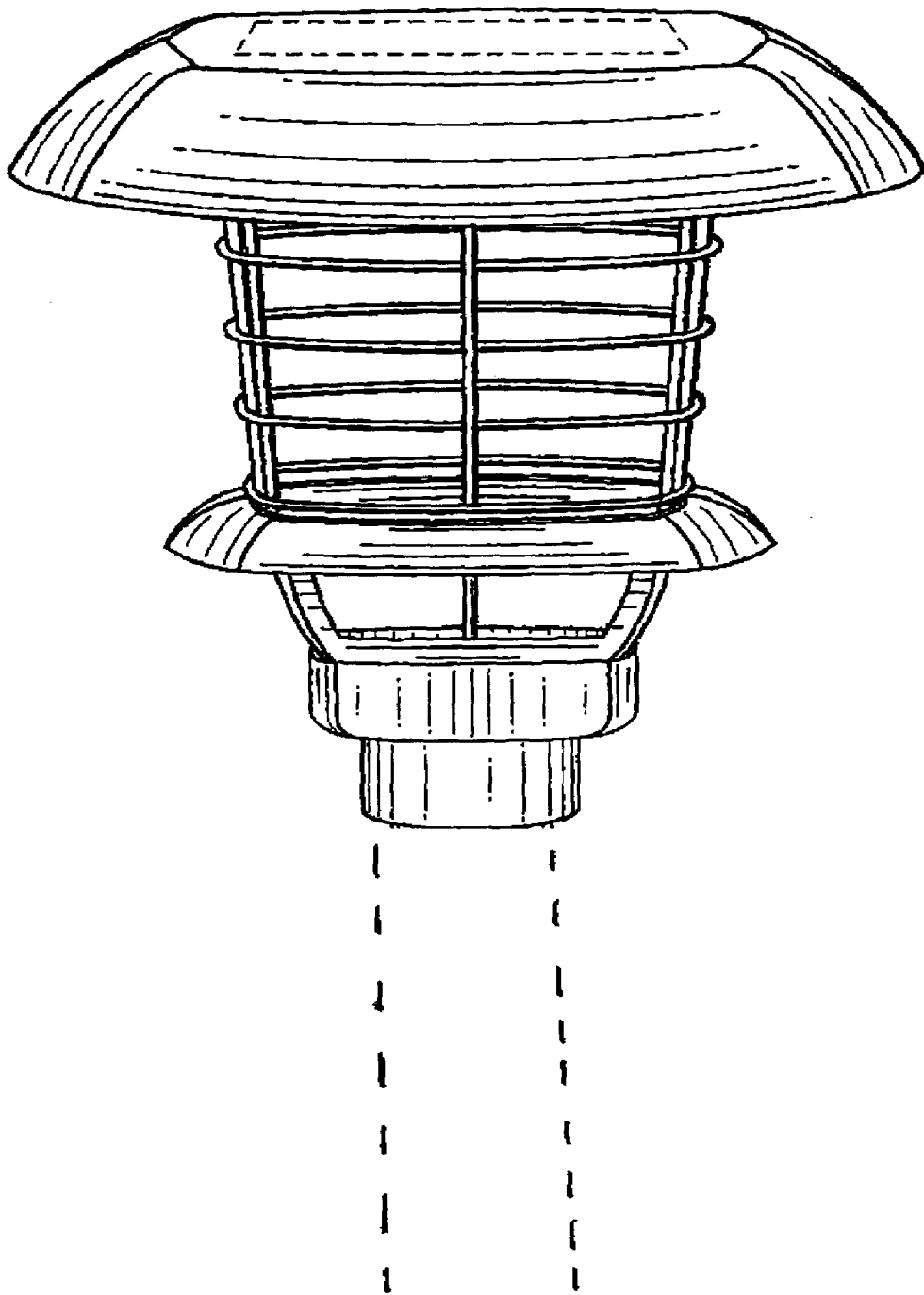

Fig. 1

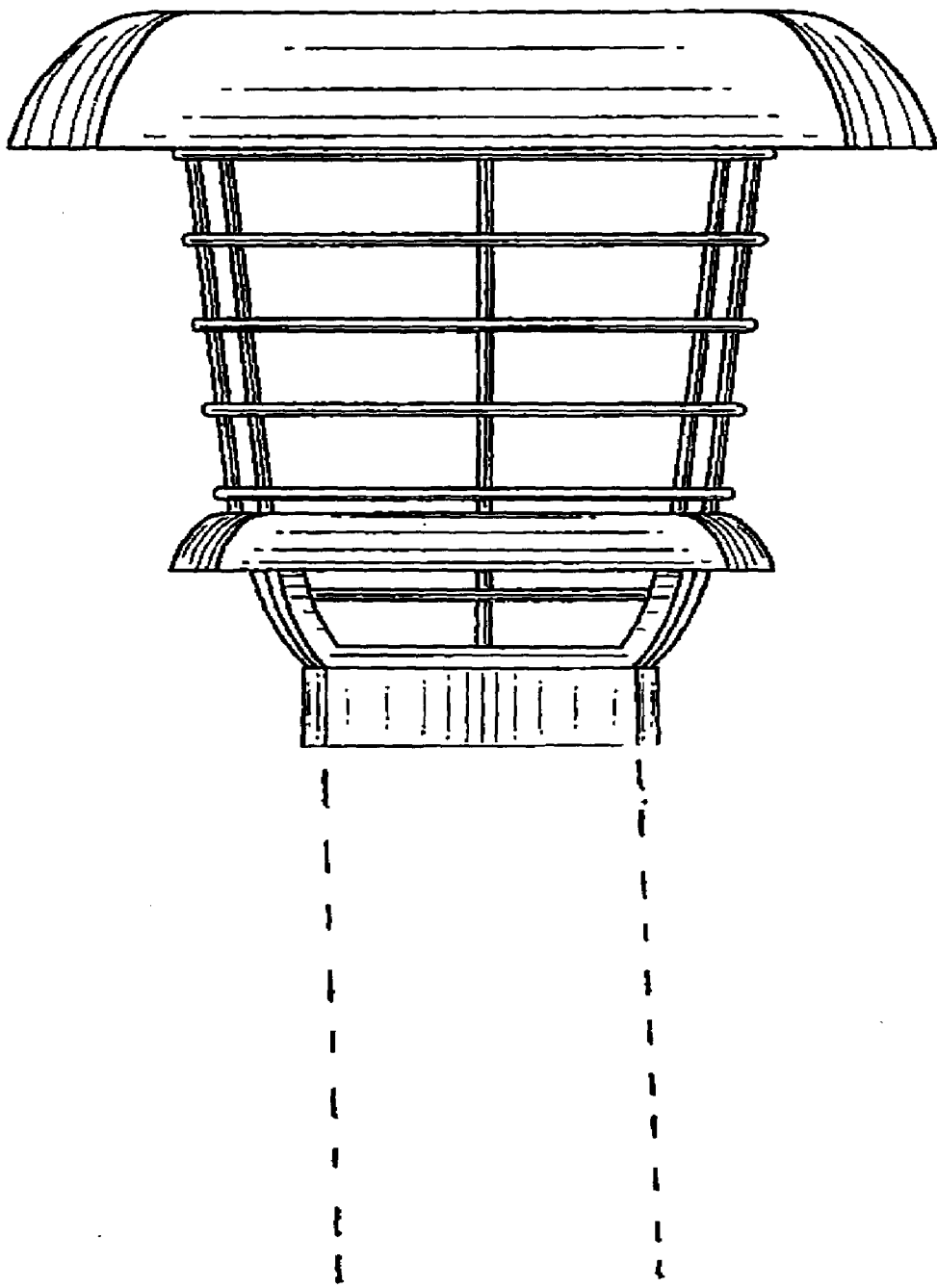

Fig. 2

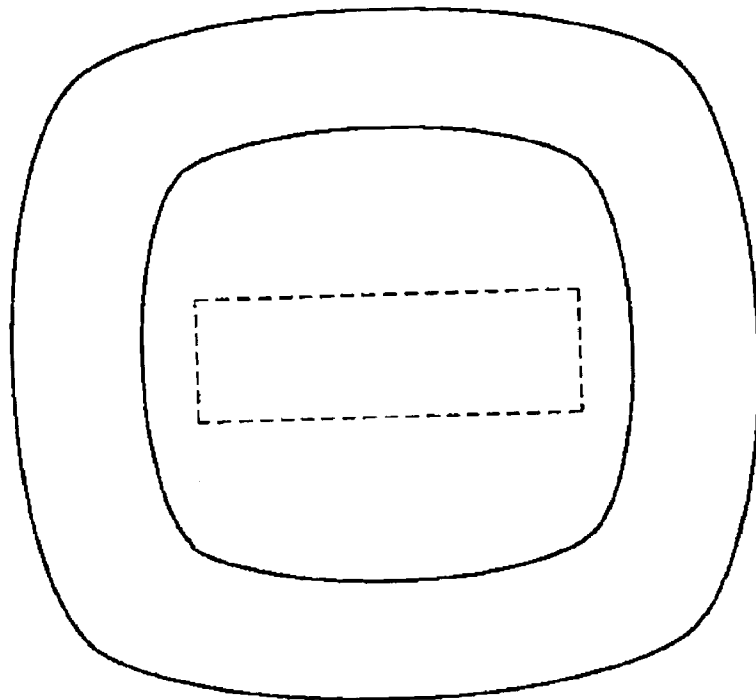

Fig. 3

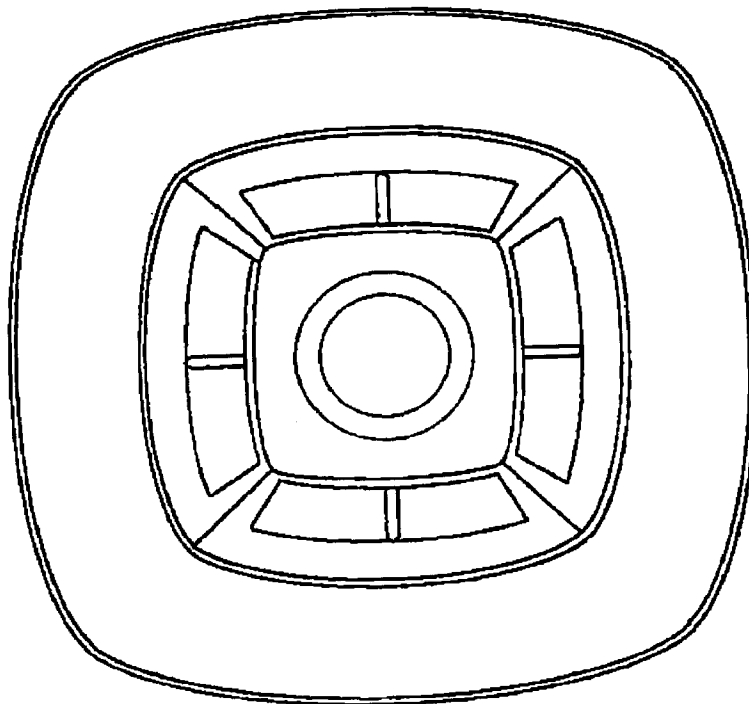

Fig. 4