

PATENT ASSIGNMENT

Electronic Version v1.1
 Stylesheet Version v1.1

SUBMISSION TYPE:	NEW ASSIGNMENT
NATURE OF CONVEYANCE:	ASSIGNMENT
CONVEYING PARTY DATA	
Name	Execution Date
Jeffrey Bannister Fernald	09/16/2010
RECEIVING PARTY DATA	
Name:	Arry Shin
Street Address:	1125 E. Olive Street
City:	Seattle
State/Country:	WASHINGTON
Postal Code:	98122
PROPERTY NUMBERS Total: 1	
Property Type	Number
Application Number:	12885197
CORRESPONDENCE DATA	
Fax Number:	(206)217-2201
<i>Correspondence will be sent via US Mail when the fax attempt is unsuccessful.</i>	
Phone:	2062172200
Email:	patents@aeonlaw.com
Correspondent Name:	Adam L.K. Philipp
Address Line 1:	1525 4th Ave Suite 800
Address Line 4:	Seattle, WASHINGTON 98101
ATTORNEY DOCKET NUMBER:	SHAR-2010004
NAME OF SUBMITTER:	Adam L.K. Philipp
Total Attachments: 29 source=20100917_Assignment_SHAR2010004#page1.tif source=20100917_Assignment_SHAR2010004#page2.tif source=20100917_Assignment_SHAR2010004#page3.tif source=20100917_Assignment_SHAR2010004#page4.tif source=20100917_Assignment_SHAR2010004#page5.tif	

OP \$40.00 12885197

source=20100917_Assignment_SHAR2010004#page6.tif
source=20100917_Assignment_SHAR2010004#page7.tif
source=20100917_Assignment_SHAR2010004#page8.tif
source=20100917_Assignment_SHAR2010004#page9.tif
source=20100917_Assignment_SHAR2010004#page10.tif
source=20100917_Assignment_SHAR2010004#page11.tif
source=20100917_Assignment_SHAR2010004#page12.tif
source=20100917_Assignment_SHAR2010004#page13.tif
source=20100917_Assignment_SHAR2010004#page14.tif
source=20100917_Assignment_SHAR2010004#page15.tif
source=20100917_Assignment_SHAR2010004#page16.tif
source=20100917_Assignment_SHAR2010004#page17.tif
source=20100917_Assignment_SHAR2010004#page18.tif
source=20100917_Assignment_SHAR2010004#page19.tif
source=20100917_Assignment_SHAR2010004#page20.tif
source=20100917_Assignment_SHAR2010004#page21.tif
source=20100917_Assignment_SHAR2010004#page22.tif
source=20100917_Assignment_SHAR2010004#page23.tif
source=20100917_Assignment_SHAR2010004#page24.tif
source=20100917_Assignment_SHAR2010004#page25.tif
source=20100917_Assignment_SHAR2010004#page26.tif
source=20100917_Assignment_SHAR2010004#page27.tif
source=20100917_Assignment_SHAR2010004#page28.tif
source=20100917_Assignment_SHAR2010004#page29.tif

A S S I G N M E N T

This Agreement is entered into between the following parties:

ASSIGNOR(S): Jeffrey Bannister Fernald, an individual,

ASSIGNEE: Arry Shin, an individual,

For good and valuable consideration, the receipt of which is hereby acknowledged, **Assignor hereby sells, assigns, transfers, and conveys to Assignee** or its designees, all right, title, and interest that exist today and may exist in the future in and to any and all items in the following categories (collectively, the "Patent Rights"):

- (a) the provisional patent applications, patent applications, and patents listed below (collectively, the "Patents"):
 - (i) ***EXTENDIBLE TABLE***, a non-provisional patent application, listing inventor(s) ***Arry Shin of Seattle, Washington; and Jeffrey Bannister Fernald, of Seattle, Washington;*** with the Attorney Docket No. SHAR-2010004, filed herewith and attached hereto;
- (b) the following additional patents and patent applications that have been or may be filed:
 - (i) all patents and patent applications from which any of the Patents directly or indirectly claims priority;
 - (ii) all patents and patent applications for which any of the Patents directly or indirectly forms a basis for priority; and/or
 - (iii) all patents and patent applications that were co-owned applications that incorporate by reference, or are incorporated by reference into, the Patents;
- (c) all applications derived from any item in any of categories (a) through (b), above, including, without limitation, divisional applications, continuation applications, continued prosecution applications, continuation-in-part applications, substitute applications, renewal applications, reissue applications, reexaminations, and extensions;
- (d) all foreign patents, patent applications, and counterparts relating to any item in any of categories (a) through (c), including, without limitation, certificates of invention, utility models, industrial design protection, design patent protection, and other governmental grants or issuances;
- (e) all inventions, disclosures, and discoveries described in any item in any of categories (a) through (d), including, without limitation, the following:
 - (i) all inventions, disclosures, and discoveries included in any claim (whether issued, rejected, withdrawn, cancelled, or the like) that is or was claimed therein;

- (ii) all inventions, disclosures, and discoveries that are capable of being reduced to a claim in a reissue or reexamination proceeding brought thereon; and/or
- (iii) all inventions, disclosures, and discoveries that could have been included in a claim therein;
- (f) all rights to apply in any or all countries for patents, certificates of invention, utility models, industrial design protections, design patent protections, or other governmental grants or issuances of any type that are related to any item in any of categories (a) through (e), including, without limitation, rights to apply under the Paris Convention for the Protection of Industrial Property, the International Patent Cooperation Treaty, or any other convention, treaty, agreement, or understanding;
- (g) all causes of action and other enforcement rights (whether known, unknown, currently pending, filed, or otherwise) under or on account of any item in any of categories (a) through (f), including, without limitation, causes of action and other enforcement rights for damages, injunctive relief, and any other remedies for past, current, and/or future infringement;
- (h) all rights to collect royalties and other payments under or on account of any item in any of categories (a) through (g); and
- (i) all rights of priority arising under or on account of any item in any of categories (a) through (f).

Assignor represents, warrants and covenants as follows:

- (1) Assignor has the full power and authority, and has obtained all required third party consents, approvals, and/or other authorizations, to enter into this Agreement and to carry out its obligations hereunder, including the assignment of the Patent Rights to Assignee;
- (2) Assignor owns, and by this Agreement assigns to Assignee, all right, title, and interest to the Patent Rights, including, without limitation, all right, title, and interest to sue for infringement of the Patent Rights;
- (3) Assignor has obtained and properly recorded previously executed assignments for the Patent Rights as necessary to fully perfect its rights and title therein in accordance with governing law and regulations in each respective jurisdiction; and
- (4) the Patent Rights are free and clear of all liens, claims, mortgages, security interests or other encumbrances, and restrictions. There are no actions, suits, investigations, claims or proceedings threatened, pending, or in progress relating in any way to the Patent Rights. There are no existing contracts, agreements, options, commitments, proposals, bids, offers, or rights with, to, or in any person to acquire any of the Patent Rights.

Assignor hereby authorizes the respective patent office or governmental agency in each jurisdiction to issue in the name of Assignee, as the assignee to the entire interest therein, any and all patents, certificates of invention, utility models, or other governmental grants or issuances that may be granted upon any of the Patent Rights.

At the reasonable request and expense of Assignee, Assignor will, without demanding any further consideration, do all things necessary, proper, or advisable to carry out in good faith the

intent and purpose of this Assignment and to assist Assignee in obtaining, perfecting, sustaining, and/or enforcing the Patent Rights, such assistance to include without limitation,

- (A) executing, acknowledging, and recording specific assignments, oaths, declarations, powers of attorney, and other documents on a country-by-country basis;
- (B) executing all divisional applications, continuation applications, continued prosecution applications, continuation-in-part applications, substitute applications, renewal applications, reissue applications, reexaminations, and extensions; and
- (C) communicating to Assignee all facts known to Assignor relating to the Patent Rights and the history thereof.

The terms and conditions of this Assignment of Patent Rights will inure to the benefit of Assignee, its successors, assigns, and other legal representatives and will be binding upon Assignor, its successors, assigns, and other legal representatives

Each Inventor: Please Sign and Date Below:

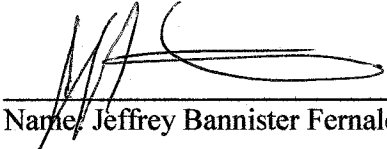
9/16, 2010 
Date Name: Jeffrey Bannister Fernald

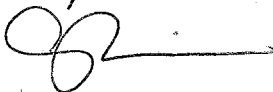
9/16/2010 

Assignment Document Return Address:

ÆON Law
1525 Fourth Avenue
Suite 800
Seattle, Washington 98101
U.S.A.

EXTENDIBLE TABLE

FIELD

[Para 01] The present disclosure relates to tables, and more particularly, to a table with a continuously extendible surface.

BACKGROUND

[Para 02] A table is a type of furniture comprising an open, flat surface supported by a base or legs. Tables are often used to hold articles (e.g., dishware, papers, books, and the like) at a convenient height when sitting, and are therefore often used in conjunction with one or more chairs. A table specifically intended for writing and office work is commonly referred to as a desk.

[Para 03] Many tables are placed in living and/or working spaces in which space is at a premium. Furthermore, in many cases, a table user might have a need for a large table only occasionally (e.g., when visitors need to be seated at the table), needing only a smaller tabletop on a day to day basis. Consequently, some tables have removable sections or leaves used to extend the surface in discrete increments. Other tables may utilize hinged extensions of the table top (commonly known as “drop leaves”). However, removable leaves can be difficult to install, and some require an external storage space to house the leaves when not in use. Drop leaves do not share these disadvantages, but drop leaves can interfere with use of the table when they are in their dropped position.

[Para 04] Many tables are also placed in multi-purpose spaces, in which some uses of the space may be more efficient without the table being present. In some cases, such multi-purpose spaces may sometimes house a portable folding table, in which the legs fold up against the underside of the table top for storage when not in use. However, many folding tables are not aesthetically pleasing. In addition, folding tables require storage space when they are not in use. Some folding tables may be light and/or easy to deploy, but suitable only for supporting light-weight articles. Other folding tables may be sturdier, but heavy and/or difficult to deploy.

BRIEF DESCRIPTION OF THE DRAWINGS

[Para 05] Figures 1-3 illustrate an exemplary extendible table in accordance with various embodiment.

[Para 06] Figures 4-5 illustrate extendible tables with various alternate support members, in accordance with various embodiments.

[Para 07] Figures 6-10 illustrate extendible tabletops with various alternate sliding guide assemblies, in accordance with various embodiments.

[Para 08] Figure 11 illustrates extendible tabletop surface configurations, in accordance with various embodiments.

DESCRIPTION

[Para 09] The phrases “in one embodiment,” “in various embodiments,” “in some embodiments,” and the like are used repeatedly. Such phrases do not necessarily refer to the same embodiment. The terms “comprising,” “having,” and “including” are synonymous, unless the context dictates otherwise.

[Para 10] Reference is now made in detail to the description of the embodiments as illustrated in the drawings. While embodiments are described in connection with the drawings and related descriptions, there is no intent to limit the scope to the embodiments disclosed herein. On the contrary, the intent is to cover all alternatives, modifications, and equivalents. In alternate embodiments, additional devices, or combinations of illustrated devices, may be added to, or combined, without limiting the scope to the embodiments disclosed herein.

[Para 11] Figure 1 illustrates an exemplary extendible table 100 in accordance with one embodiment. Extendible table 100 includes a lower tabletop 105 and an upper tabletop 110 configured to slide across lower tabletop 105 along an extension path 185. Lower tabletop 105 and upper tabletop 110 form in combination a combined tabletop surface that may be extended horizontally as upper tabletop 110 slides along extension path 185.

[Para 12] An edge 135 of upper tabletop 110 delineates portions 140 and 145 of lower tabletop 105. Portion 145 of lower tabletop 105 overlaps with a portion of upper tabletop 110, while portion 140 of lower tabletop 105 does not overlap with any of upper

tabletop 110. The sizes of portions 140 and 145 change as upper tabletop 110 (and thus edge 135) slides along extension path 185.

[Para 13] The length of the combined tabletop is continuously variable between a minimum length (when upper tabletop 110 is fully retracted and non-overlapping portion 140 is smaller or even non-existent) and a maximum usable length (when upper tabletop 110 is extended as far as practicable and overlapping portion 145 is smaller).

[Para 14] In some embodiments, the thickness of upper tabletop 110 at edge 135 may be about 5mm or less, such that the combined tabletop surface remains substantially continuous, with only a small discontinuity across edge 135. In one embodiment, upper tabletop 110 may be fabricated from 18-gauge stainless steel. In one embodiment, In some embodiments, the thickness of upper tabletop 110 may not be uniform. (See, e.g., Figs. 10a-b, discussed below.)

[Para 15] In various embodiments, lower tabletop 105 and/or upper tabletop 110 may be formed of wood, engineered wood (e.g., plywood, particleboard, fiberboard, laminated veneer lumber, and the like), cardboard, plastic, metal, glass, or any other suitable solid material. In one embodiment, lower tabletop 105 is formed primarily of wood or engineered wood, while upper tabletop 110 is formed primarily of sheet metal (e.g. steel).

[Para 16] As sheet metal tends to be much stiffer than wood or engineered wood, upper tabletop 110 can thus be much thinner compared to lower tabletop 105, yet still retain at least a comparable stiffness. For example, some forms of plywood may have a Young's modulus of approximately 8 GPa, while steel may have a Young's modulus of approximately 200 GPa (an order of magnitude or more greater than that of some forms of plywood). As a result, sheet steel with a thickness of about 1mm may be roughly as stiff as plywood with a thickness of about 25mm or 1 inch. In some embodiments, this disparity may allow for at least the edge 135 of upper tabletop 110 to have a thickness of 1mm (or possibly even less if the thickness of upper tabletop 110 is "feathered" toward edge 135).

[Para 17] In the illustrated embodiment, lower tabletop 105 and upper tabletop 110 are supported in a horizontal position (when extendible table 100 is in use) by a pair of legs 115A-B at one end of lower tabletop 105, and a lateral fixed support member 120 at

the other end of lower tabletop 105. Fixed lateral support member 120 is at least partially supported by optional mount 125, which, if present, may be affixed to floor 175. In some embodiments, fixed lateral support member 120 may further be affixed to floor 175, wall 180, or to other supportive horizontal or vertical surface via additional mounting hardware (e.g. 187).

[Para 18] In the illustrated embodiment, extendible table 100 is configured to slide back and forth along fixed lateral support member 120, continuously traversing lateral sliding path 190. In the illustrated embodiment, extendible table 100 is also configured to pivot about fixed lateral support member 120 through a pivoting path 195 between the illustrated in-use horizontal position and a not-in-use vertical stowed position (see Figure 3, discussed below). In some embodiments, upper tabletop 110 may optionally have an end cap 112 that may hold upper tabletop 110 in its stowed position when extendible table is positioned vertically.

[Para 19] In the illustrated embodiment, legs 115A-B are also configured to fold flat along the underside of lower tabletop 105 when extendible table 100 is stowed in a vertical position. When extendible table 100 is deployed for use in the illustrated horizontal position, optional rotatable support-member stabilizer feet 130A-B are rotated to stabilize legs 115A-B along floor 175.

[Para 20] Figure 2, illustrates extendible table 100 supporting loads on various portions of lower tabletop 105 and upper tabletop 110, in accordance with one embodiment. Non-overlapping portion 140 of lower tabletop 105 is capable of supporting a load (e.g., tabletop item 280A). Similarly, the portion 250 of upper tabletop 110 that extends beyond lower tabletop 105 is also capable of supporting a load (e.g., tabletop item 280C). A tabletop item (e.g. 280B) may also be useably supported across edge 135, edge 135 being thin enough that item 280B may still be used when positioned across the edge discontinuity in the combined tabletop surface.

[Para 21] Figure 3 illustrates extendible table 100 stowed in a substantially vertical position against wall 180 when not in use, in accordance with one embodiment. In some embodiments, a latch (not shown) may secure extendible table 100 in its stowed position. In other embodiments, extendible table 100 may pivot a degree or more past vertical, to lean back against wall 180 such that gravity and/or friction may suffice to hold extendible

table 100 in its stowed position. In some embodiments, upper tabletop 110 may optionally have an end cap 112 that may hold upper tabletop 110 in its stowed position when extendible table is positioned vertically.

[Para 22] Legs 115A-B are hinged to one end of lower tabletop 105 via leg mounting blocks 375A-B and leg-pivot crosspiece 380, which allow legs 115A-B to hang in a roughly vertical position as extendible table 100 pivots between its in-use horizontal position (in which legs 115A-B are substantially perpendicular to the table surface) and its stowed vertical position (in which legs 115A-B are substantially parallel to the table surface). In other embodiments, other hinge mechanisms may be employed. In some embodiments, optional rotatable support-member stabilizer feet 130A-B are rotated to allow legs 115A-B to sit approximately flush against the underside of lower tabletop 105. In some embodiments, legs 115A-B may be usable as handles to pivot extendible table 100 back and forth between the in-use horizontal position and the stowed vertical position.

[Para 23] Lower tabletop 105 is mounted to fixed lateral support member 120 via lateral-support mounts 365A-B, which allow extendible table 100 to slide back and forth across at least a portion of fixed lateral support member 120, traversing lateral sliding path 190. In one embodiment, lateral-support mounts 365A-B have a slot 370 to allow them to slide over mount 125 when extendible table 100 is deployed in the horizontal in-use position. In some embodiments, lateral-support mounts 365A-B also allow extendible table 100 to pivot about fixed lateral support member 120. In other embodiments, other hinge and/or pivot mechanisms may be employed.

[Para 24] In some embodiments, fixed lateral support member 120 may further be affixed to floor 175, wall 180, or to other supportive horizontal or vertical surface via additional mounting hardware (e.g. 385).

[Para 25] In various embodiments, extendible tables may be supported in a usable horizontal position via various alternate supporting structures. For example, Figures 4a and 4b illustrate freestanding extendible tables 400A and 400B in accordance with alternate embodiments. Extendible table 400A is supported in a substantially horizontal position by legs 415A-B, affixed to the underside of upper tabletop 410, and by legs 415C-D, affixed to the underside of lower tabletop 405. Similarly, extendible table 400B

is supported in a substantially horizontal position by legs 415A-B, affixed to the underside of upper tabletop 410, and by legs 415C-D, affixed to one end of the underside of lower tabletop 405. Extendible table 400B adds an additional leg 415E affixed towards the other end of the underside of lower tabletop 405. In other embodiments, more or fewer legs or other suitable supporting structures may be employed. In some embodiments, upper tabletop 410 may optionally have an end cap 412. Extendible table 400C is supported in a substantially horizontal position by legs 415A-B and 415F-G, all of which are affixed to the underside of lower tabletop 405, such that upper tabletop 410 may extend across proximal end 420 of lower tabletop 405 or distal end 425 of lower tabletop 405.

[Para 26] Figure 5 illustrates freestanding extendible table 500 in accordance with one embodiment. Extendible table 500 is supported in a substantially horizontal position by support leg 515 and support base 520.

[Para 27] Extendible table 500 includes a lower tabletop 505 and upper tabletops 510A-B configured to slide across lower tabletop 505 along extension paths 585A-B, respectively. Lower tabletop 505 and upper tabletops 510A-B form in combination a combined tabletop surface that may be extended horizontally as upper tabletops 510A-B slides along extension paths 585A and/or 585B, respectively.

[Para 28] Figures 6-10 illustrate, among other things, several alternative sliding guide configurations, in accordance with various embodiments. In accordance with various embodiments, sliding guides are configured to constrain an upper tabletop to slide across a lower tabletop along a particular extension path. Sliding guides are generally further configured to prevent the upper tabletop from tilting as it is extended, maintaining a substantially continuous combined tabletop surface. In some embodiments, a sliding guide may be further configured to prevent the upper tabletop from extending too far.

[Para 29] The sliding guide configurations illustrated in Figures 6-10 are not an exhaustive survey of all possible sliding guide configurations. Rather, the sliding guide configurations shown in Figures 6-10 are merely illustrative examples, and in other embodiments, other sliding guide configurations may be employed according to similar principles. In various embodiments, various sliding guide features illustrated in

Figures 6-10 may be combined with various support and/or pivoting features as illustrated in Figures 1-5, as well as various tabletop features as illustrated in Figures 11a-f, to form a variety of extendible table configurations.

[Para 30] Figure 6 illustrates an embodiment of an extendible tabletop 600, in which upper tabletop 610 is constrained to slide along extension path 685 by a sliding guide assembly comprising flanges 615A-B and sub-flanges 620A-B, which slide along edges 625A-B of lower tabletop 605. Flanges 615A-B depend from upper tabletop 610 and are substantially parallel to edges 625A-B. In this embodiment, edges 625A-B are also parallel to each other at least along extension path 685. Sub-flanges 620A-B slide along the lower surface 630 (or the underside) of lower tabletop 605 and prevent upper tabletop 610 from tilting as it extends for at least some distance beyond lower tabletop 605. In various embodiments, sub-flanges 620A-B may extend for various distances across the lower surface 630 of lower tabletop 605. In some embodiments, In some embodiments, sub-flanges 620A-B may extend across the entire lower surface 630 of lower tabletop 605, the upper tabletop 610 thereby completely wrapping around at least four sides of lower tabletop 605. In other embodiments, as illustrated in Figure 6, the upper tabletop 610 wraps around an upper surface (not shown) and edges 625A-B of lower tabletop 605, extending across only a portion of lower surface 630 of lower tabletop 605. In some embodiments, if upper tabletop 610 is extended too far beyond lower tabletop 605, a usable extension range may be exceeded, and sub-flanges 620A-B may be ineffective to prevent upper tabletop 610 from tilting. In some embodiments, extendible tabletop 600 may also comprise a restriction mechanism (not shown) to prevent upper tabletop 610 from extending beyond a usable extension range. In some embodiments, upper tabletop 610 may further comprise an end cap (not shown) covering the open end of upper tabletop 610 (see, e.g., upper tabletops 110 and 410 in Figures 1-2 and 4).

[Para 31] Figure 7 illustrates an embodiment of an extendible tabletop 700, in which upper tabletop 710 is constrained to slide along extension path 785 by a sliding guide assembly comprising flanges 715A-B and sub-flanges 720A-B, which slide along grooves 726A-B in edges 725A-B of lower tabletop 705. Flanges 715A-B depend from upper tabletop 710 and are substantially parallel to edges 725A-B. In this embodiment,

edges 725A-B are also parallel to each other at least along extension path 785. Sub-flanges 720A-B slide in grooves 726A-B of lower tabletop 705 and prevent upper tabletop 710 from tilting as it extends for at least some distance beyond lower tabletop 705. In some embodiments, if upper tabletop 710 is extended too far beyond lower tabletop 705, a usable extension range may be exceeded, and sub-flanges 720A-B may be ineffective to prevent upper tabletop 710 from tilting. In some embodiments, extendible tabletop 700 may also comprise a restriction mechanism (not shown) to prevent upper tabletop 710 from extending beyond a usable extension range.

[Para 32] Figures 8a-b shows perspective views from below and above of an embodiment of an extendible tabletop 800, in which upper tabletop 810 is constrained to slide along extension path 885 by a sliding guide assembly comprising flanges 815A-B and sub-flanges 820A-B, which slide along “T”-shaped grooves 825A-B in the upper surface 840 of lower tabletop 805. Flanges 815A-B depend from the lower surface 850 of upper tabletop 810 and are substantially parallel to grooves 825A-B. In the illustrated embodiment, edges 855A-B and 860A-B (of lower tabletop 805 and upper tabletop 810, respectively) are substantially parallel to one another. In other embodiments, when none of edges 855A-B and 860A-B form part of the sliding guide assembly, edges 855A-B and 860A-B need not be parallel to one another. Sub-flanges 820A-B slide in the transverse portions of “T”-shaped grooves 825A-B of lower tabletop 805 and prevent upper tabletop 810 from tilting as it extends for at least some distance beyond lower tabletop 805. In some embodiments, if upper tabletop 810 is extended too far beyond lower tabletop 805 (i.e., if the overlapping portions of lower tabletop 805 and upper tabletop 810, as delineated by edge 835, become too small), a usable extension range may be exceeded, and sub-flanges 820A-B may be ineffective to prevent upper tabletop 810 from tilting. In some embodiments, extendible tabletop 800 may also comprise a restriction mechanism (not shown) to prevent upper tabletop 810 from extending beyond a usable extension range.

[Para 33] Figures 9a-b shows perspective views from below and above of an embodiment of an extendible tabletop 900, in which upper tabletop 910 is constrained to slide along extension path 985 by a sliding guide assembly comprising tongues 915A-B, which slide along wedge-shaped grooves 925A-B in the upper surface 940 of lower

tabletop 905, similar to a loose sliding dovetail joint. Tongues 915A-B depend from the lower surface 950 of upper tabletop 910 and are substantially parallel to grooves 925A-B. In the illustrated embodiment, edges 955A-B and 960A-B (of lower tabletop 905 and upper tabletop 910, respectively) are substantially parallel to one another. In other embodiments, when none of edges 955A-B and 960A-B form part of the sliding guide assembly, edges 955A-B and 960A-B need not be parallel to one another. Tongues 915A-B slide along wedge-shaped grooves 925A-B and prevent upper tabletop 910 from tilting as it extends for at least some distance beyond lower tabletop 905. In some embodiments, if upper tabletop 910 is extended too far beyond lower tabletop 905 (i.e., if the overlapping portions of lower tabletop 905 and upper tabletop 910, as delineated by edge 935, become too small), a usable extension range may be exceeded, and sub-flanges 920A-B may be ineffective to prevent upper tabletop 910 from tilting. In some embodiments, extendible tabletop 900 may also comprise a restriction mechanism (not shown) to prevent upper tabletop 910 from extending beyond a usable extension range.

[Para 34] Figures 10a-b shows perspective views from below and above of an embodiment of an extendible tabletop 1000, in which upper tabletop 1010 is constrained to slide along extension path 1085 by a sliding guide assembly comprising tongues 1015A-B, which slide along wedge-shaped grooves 1025A-B in the upper surface 1040 of lower tabletop 1005, similar to a loose sliding dovetail joint. Tongues 1015A-B depend from the lower surface 1050 of upper tabletop 1010 and are substantially parallel to grooves 1025A-B. In the illustrated embodiment, edges 1055A-B and 1060A-B (of lower tabletop 1005 and upper tabletop 1010, respectively) are substantially parallel to one another. Tongues 1015A-B slide along wedge-shaped grooves 1025A-B and prevent upper tabletop 1010 from tilting as it extends for at least some distance beyond lower tabletop 1005. In some embodiments, as illustrated in Figures 10a-b, upper tabletop 1010 may comprise a thin edge 1035 (having a small height 1055A), a sloping upper-surface portion 1045A, and a flat upper-surface portion 1045B (having a larger height 1055B). In such embodiments, thin edge 1035 and sloping upper-surface portion 1045A may allow a smooth transition between the upper surface 1040 of lower tabletop 1005 and the flat upper-surface portion 1045B of upper tabletop 1010, thereby maintaining a substantially continuous combined tabletop surface.

Such embodiments may be desirable if upper tabletop 1010 is to be fabricated from wood, engineered wood, or other material that has a relatively low stiffness compared to an upper tabletop material such as sheet steel.

[Para 35] Figures 11a-f show overhead views of several alternative tabletop configurations, in accordance with various embodiments. The tabletop configurations illustrated in Figures 11a-f are not an exhaustive survey of all possible tabletop configurations. Rather, the tabletop configurations shown in Figures 11a-f are merely illustrative examples, and in other embodiments, other tabletop configurations may be employed according to similar principles. In various embodiments, various sliding guide features illustrated in Figures 6-10 may be combined with various support and/or pivoting features as illustrated in Figures 1-5, as well as various tabletop features as illustrated in Figures 11a-f, to form a variety of extendible table configurations.

[Para 36] As illustrated in Figure 11a, one or both of upper tabletop 1110A and lower tabletop 1105A may have a curved portion. Similarly, as illustrated in Figure 11b, one or both of upper tabletop 1110A and lower tabletop 1105A may have a regular portion (e.g., 1120, 1115) with parallel sides, and an irregular portion (e.g., 1125-1130) without parallel sides. Additionally, upper tabletop 1110A and lower tabletop 1105A may have different shapes from one another.

[Para 37] As illustrated in Figure 11c, upper tabletop 1110A and lower tabletop 1105A may have parallel sides or edges that are not straight lines, but concentric circular arcs. In such embodiments, extension path 1115C may therefore also trace a circular arc.

[Para 38] As illustrated in Figure 11d, upper tabletop 1110D may be configured to extend extendible table's width by traversing extension path 1185D along lower tabletop 1105D.

[Para 39] As illustrated in Figure 11e, upper tabletop 1110E may have more than one edge (e.g. 1135A-B) that traverses a portion of the upper surface of lower tabletop 1110E. Additionally, traversing edges (e.g. 1135A-B) may not be parallel to one another or to traversed edges 1140A-B of lower tabletop 1110E.

[Para 40] As illustrated in Figure 11f, in embodiments having sliding guides that do not rely on parallel edges, upper tabletop 1110F and lower tabletop 1110F may have as

few as zero edges that are parallel (or perpendicular) to one another. Additionally, in such embodiments, extension path 1185F may not be parallel (or perpendicular) to any edge of upper tabletop 1110F or lower tabletop 1110F.

[Para 41] Although specific embodiments have been illustrated and described herein, a whole variety of alternate and/or equivalent implementations may be substituted for the specific embodiments shown and described without departing from the scope of the present disclosure. This application is intended to cover any adaptations or variations of the embodiments discussed herein.

CLAIMS:

Claim 1. An extendible table comprising:

a lower load-supporting tabletop having lower-tabletop upper and lower surfaces and at least one lower-tabletop edge;

an upper load-supporting tabletop, slidably overlapping said lower load-supporting tabletop, having:

an upper-tabletop lower surface slidably engaged with said lower-tabletop upper surface;

at least one sliding guide constraining said upper-tabletop lower surface to slide continuously along a sliding extension path traversing at least a portion of said lower-tabletop upper surface;

at least one upper-tabletop edge, less than about 5mm thick, that traverses at least a portion of said lower-tabletop upper surface as said upper-tabletop lower surface traverses said sliding extension path, said at least one upper-tabletop edge delineating variable overlapping and non-overlapping portions of said lower-tabletop upper surface; and

an upper-tabletop upper surface that forms in combination with said non-overlapping portions of said lower-tabletop upper surface a substantially continuous combined-tabletop surface having an extendible combined-tabletop horizontal dimension that varies continuously as said upper-tabletop lower surface traverses said sliding extension path; and

at least one support member affixed to a selected one of said lower tabletop and said upper tabletop to support said combined-tabletop surface in a substantially horizontal position when the extendible table is in use.

Claim 2. The extendible table of Claim 1, wherein said at least one lower-tabletop edge comprises two parallel edges that are substantially parallel to said sliding extension path, and wherein said at least one sliding guide comprises at least one flange that depends from said upper tabletop and slides along at least one of said two parallel edges.

Claim 3. The extendible table of Claim 2, wherein said at least one flange further comprises a sub-flange parallel to said lower-tabletop upper surface and configured to prevent said upper tabletop from tilting as a portion of said upper tabletop is slid to extend beyond said lower tabletop.

Claim 4. The extendible table of Claim 3, wherein said at least one flange and said at least one sub-flange in combination wrap around said two parallel edges and extend across at least a portion of a lower-tabletop lower surface.

Claim 5. The extendible table of Claim 2, wherein said sliding extension path runs in a selected one of a straight line and a circular arc.

Claim 6. The extendible table of Claim 1, wherein said lower tabletop further comprises at least one groove parallel to said sliding extension path, and wherein said at least one sliding guide comprises at least one tongue that depends from said upper tabletop and slides in said at least one groove.

Claim 7. The extendible table of Claim 1, wherein said at least one support member further comprises a support-member stabilizer rotatably mounted at a lower end of said at least one support member.

Claim 8. The extendible table of Claim 1, further comprising a fixed support member pivotably engaged with a fixed-support mount near a proximal end of a selected one of said lower tabletop and said upper tabletop, said extendible table being configured to pivot about said fixed support member between said substantially horizontal position when the extendible table is in use, and a substantially vertical position when the extendible table is not in use.

Claim 9. The extendible table of Claim 8, wherein said at least one support member is hinged near a distal end of a selected one of said lower tabletop and said upper tabletop, said at least one support member being configured to remain in a substantially vertical disposition, substantially perpendicular to said combined-tabletop when the extendible

table is in use, and substantially parallel to said combined-tabletop when the extendible table is in use.

Claim 10. The extendible table of Claim 1, further comprising a fixed lateral support member slidably engaged with a lateral-support mount near a proximal end of a selected one of said lower tabletop and said upper tabletop, said extendible table being configured to slide continuously along a sliding lateral path traversing at least a portion of said lateral support member.

Claim 11. The extendible table of Claim 10, wherein said fixed lateral support member is affixed to at least one supportive horizontal or vertical surface via at least one surface mount attached to a portion of said lateral support member traversed by said sliding lateral path, and wherein said lateral-support mount is slotted to slide around said at least one surface mount.

Claim 12. The extendible table of Claim 1, wherein said lower load-supporting tabletop is formed primarily from a first material having a first tensile modulus value, and wherein said upper load-supporting tabletop is formed primarily from a second material having a second tensile modulus value at least an order of magnitude greater than said first tensile modulus value.

Claim 13. The extendible table of Claim 1, wherein said lower load-supporting tabletop is formed primarily from wood or engineered wood, and wherein said upper load-supporting tabletop is formed primarily from sheet metal.

Claim 14. The extendible table of Claim 1, wherein the extendible table is freestanding.

Claim 15. An extendible table comprising:

lower supporting means for supporting one or more tabletop items on a lower tabletop surface;

upper supporting means for supporting said one or more tabletop items on an upper tabletop surface;

sliding means for sliding at least a portion of said upper supporting means across at least a portion of said lower supporting means along a sliding extension path to form in combination a substantially continuous combined-tabletop surface having an extendible combined-tabletop horizontal dimension that varies continuously as said upper supporting means traverses said sliding extension path; and

supporting means for supporting said combined-tabletop surface in a substantially horizontal position when the extendible table is in use.

Claim 16. The extendible table of Claim 15, further comprising table-pivoting means for pivoting the extendible table between said substantially horizontal position when the extendible table is in use, and a substantially vertical position when the extendible table is not in use.

Claim 17. The extendible table of Claim 16, further comprising hinge means for disposing said supporting means in a substantially vertical position when the extendible table is in use in said substantially horizontal position and when the extendible table is not in use in said substantially vertical position.

Claim 18. The extendible table of Claim 17, further comprising support-stabilizing means for stabilizing said supporting means when said supporting means are in said substantially vertical position.

Claim 19. The extendible table of Claim 15, further comprising lateral sliding means for sliding the extendible table along a sliding lateral path.

Claim 20. The extendible table of Claim 19, further comprising mounting means for fixing said lateral sliding means to a supportive horizontal or vertical surface.

ABSTRACT

Provided herein are extendible table apparatuses.

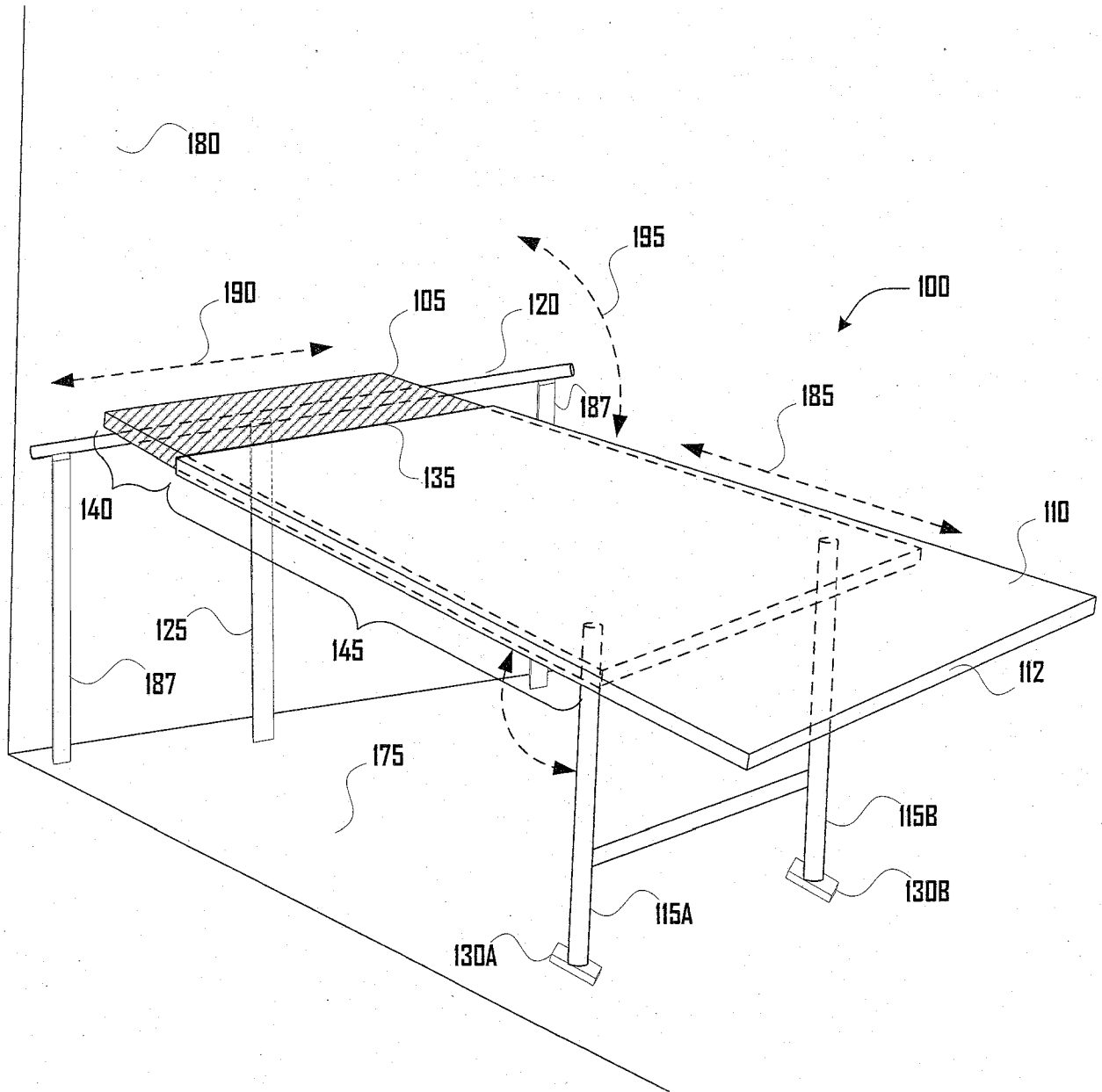

Fig. 1
PATENT

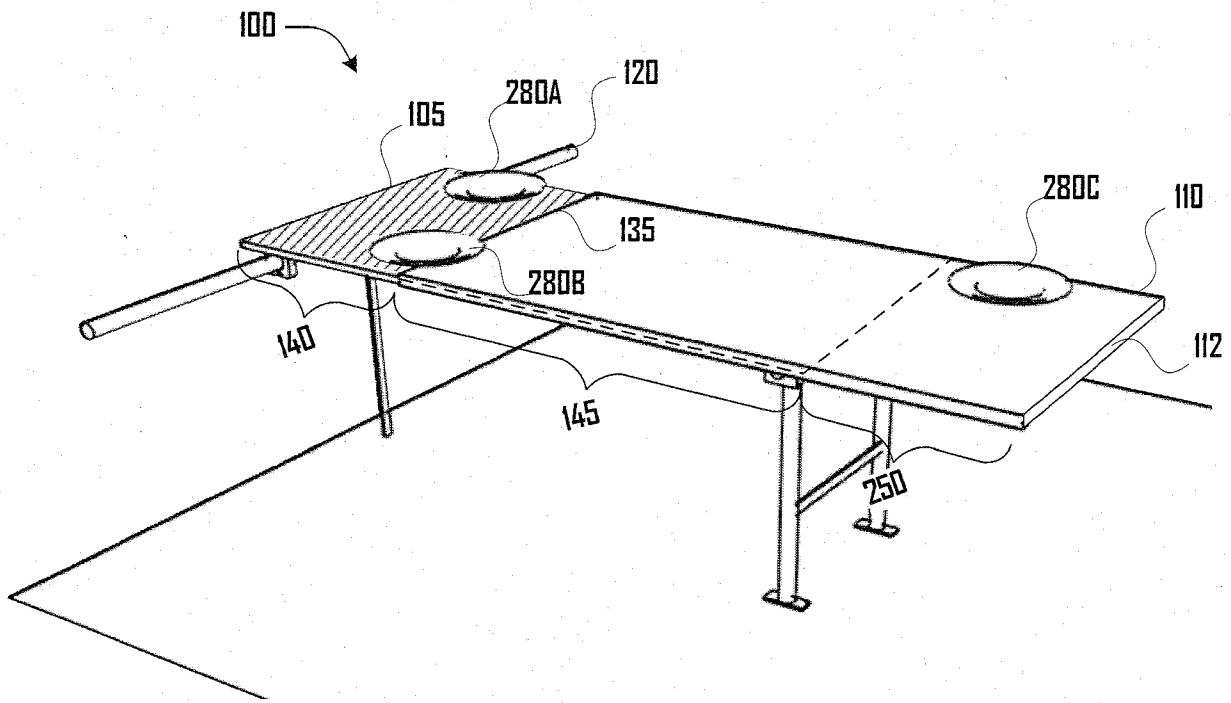

Fig. 2

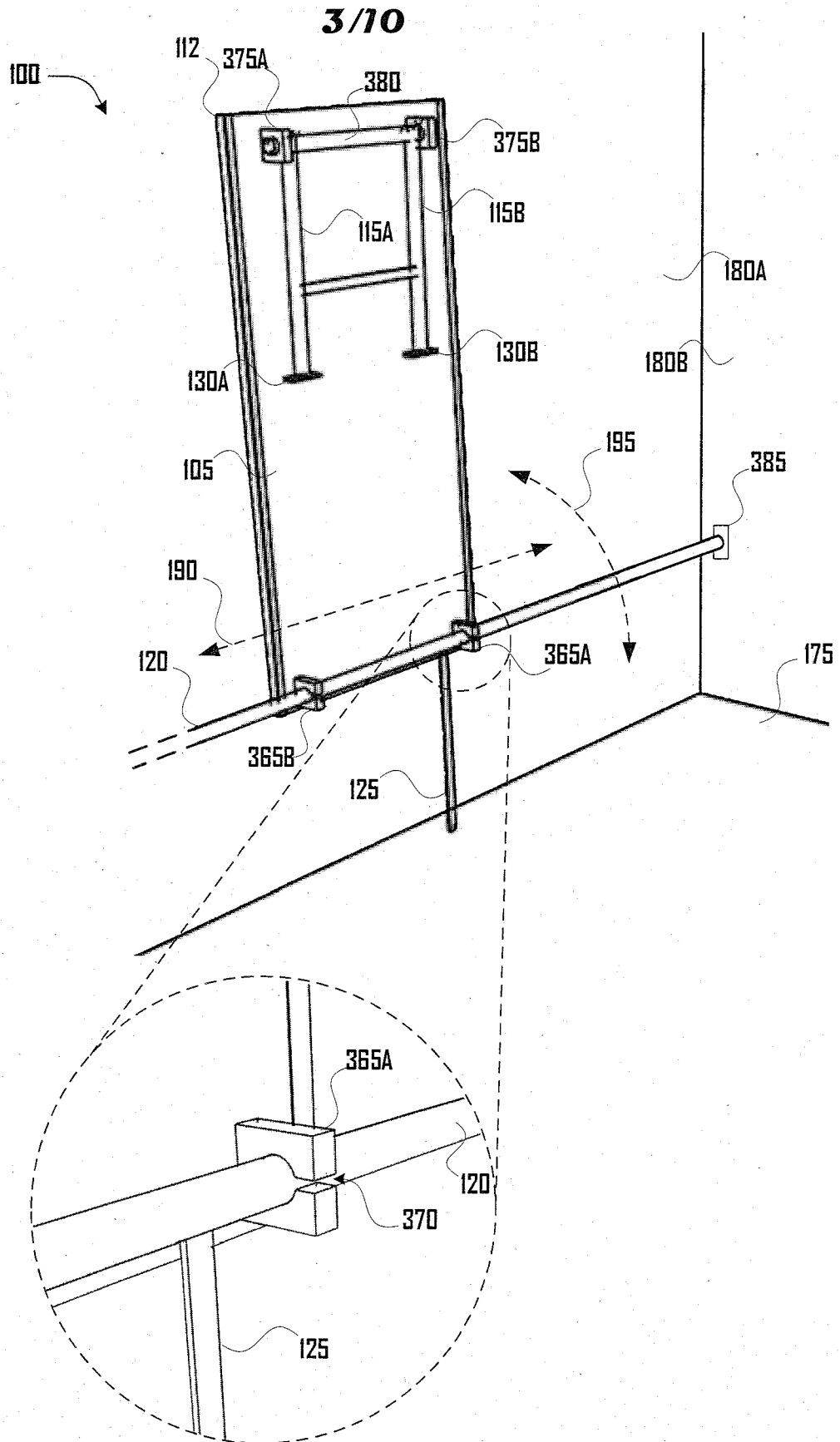
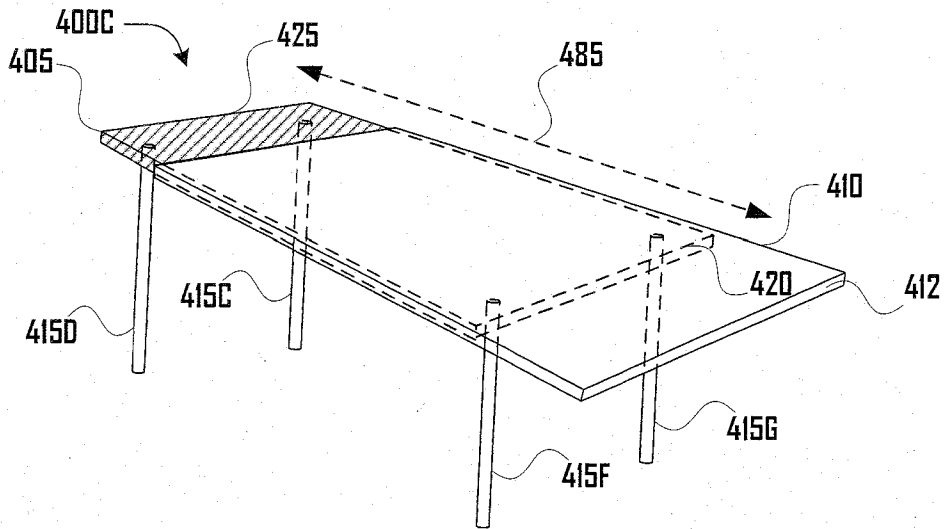
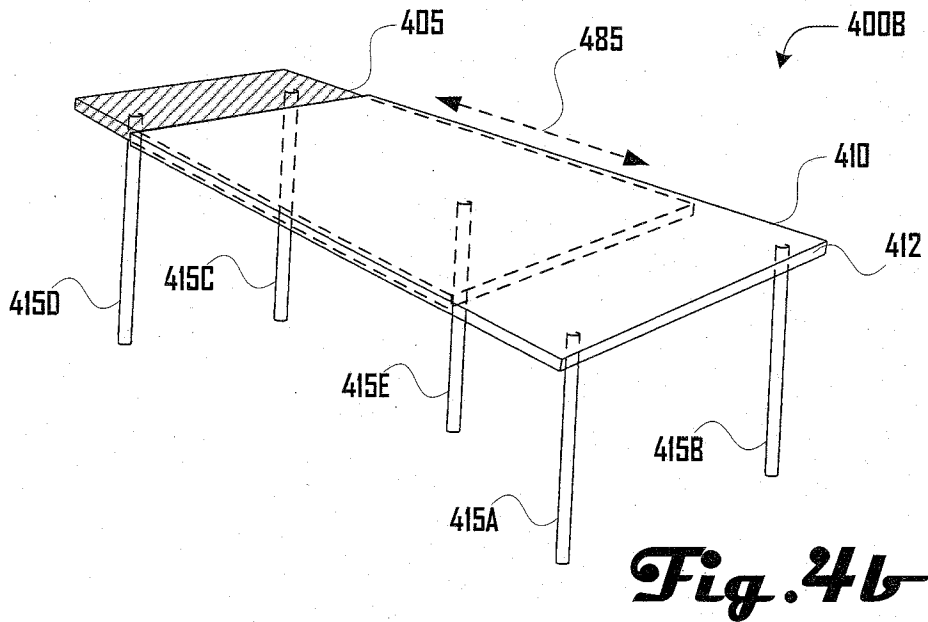
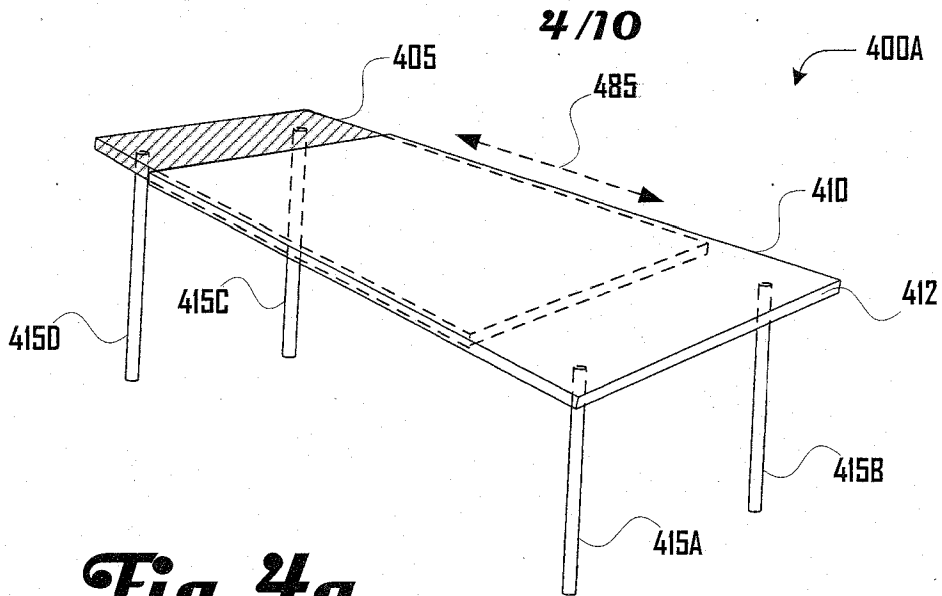

Fig. 3

PATENT

REEL: 025007 FRAME: 0965



5/10

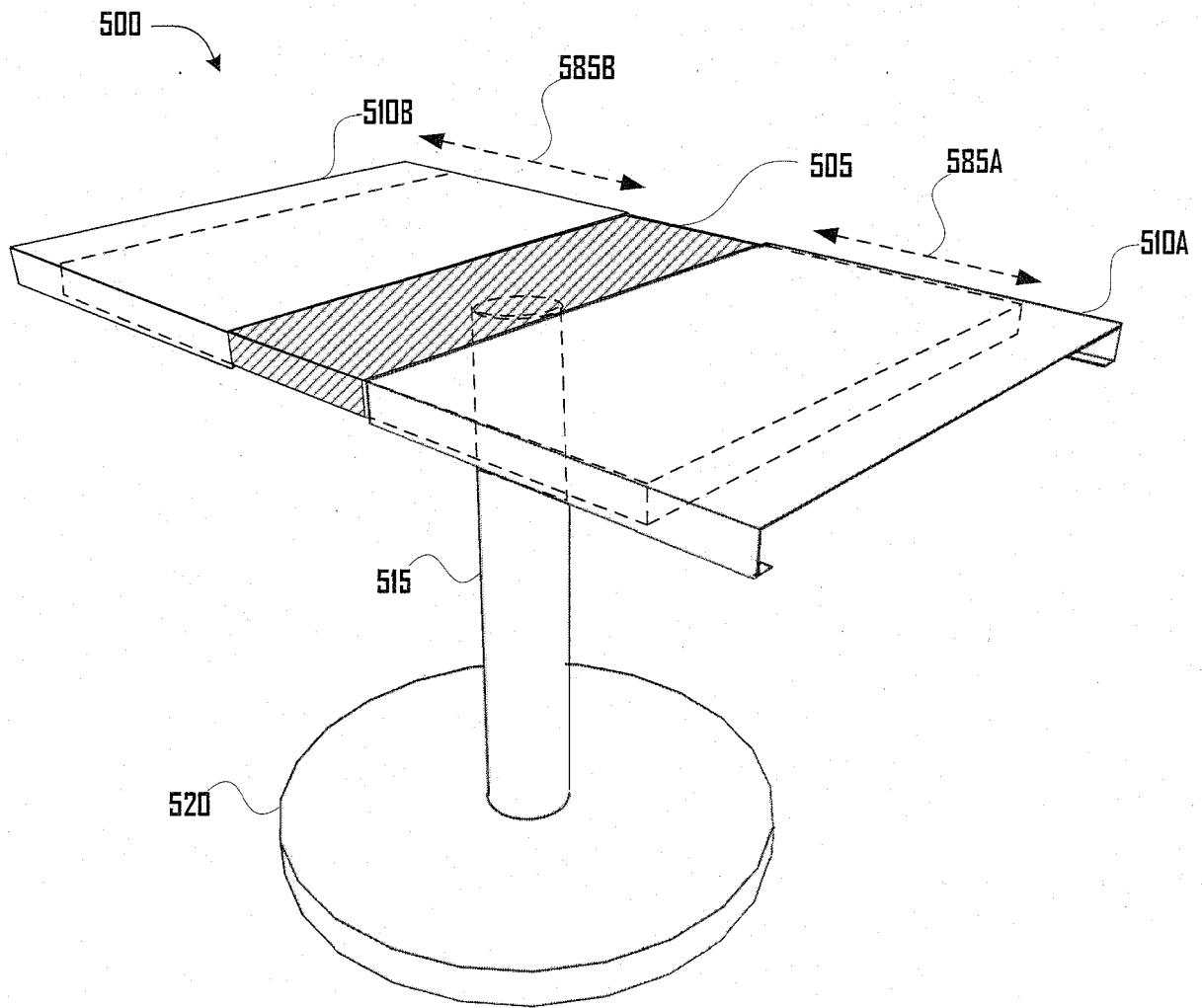

Fig. 5

6/10

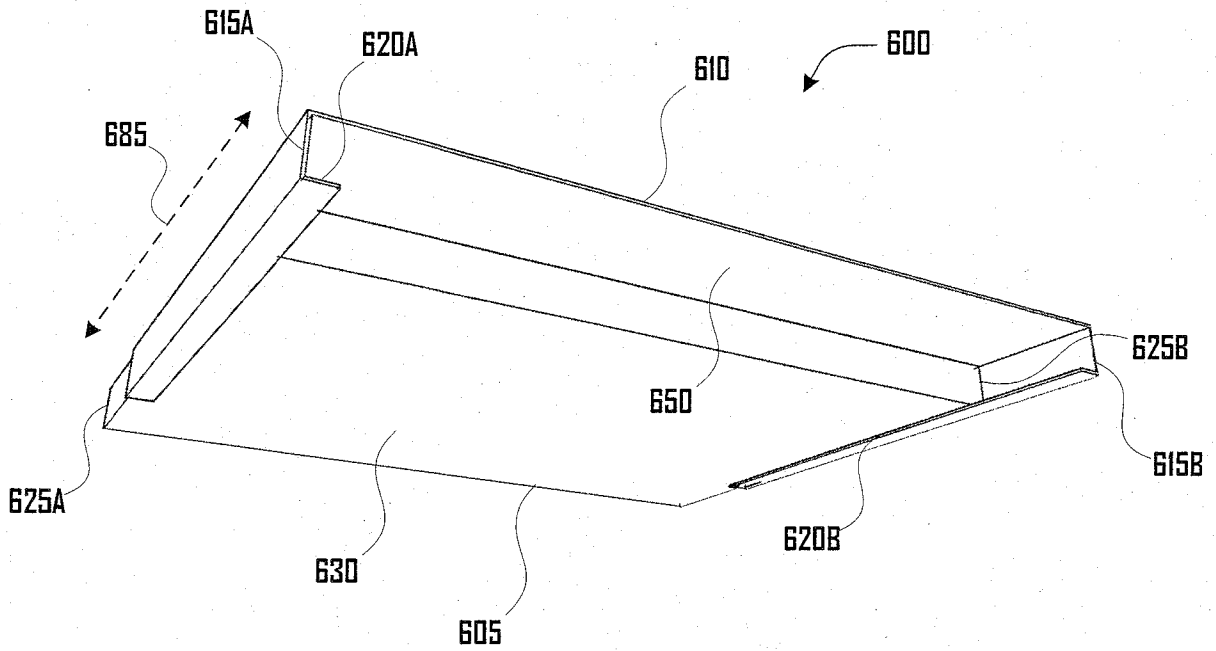

Fig. 6

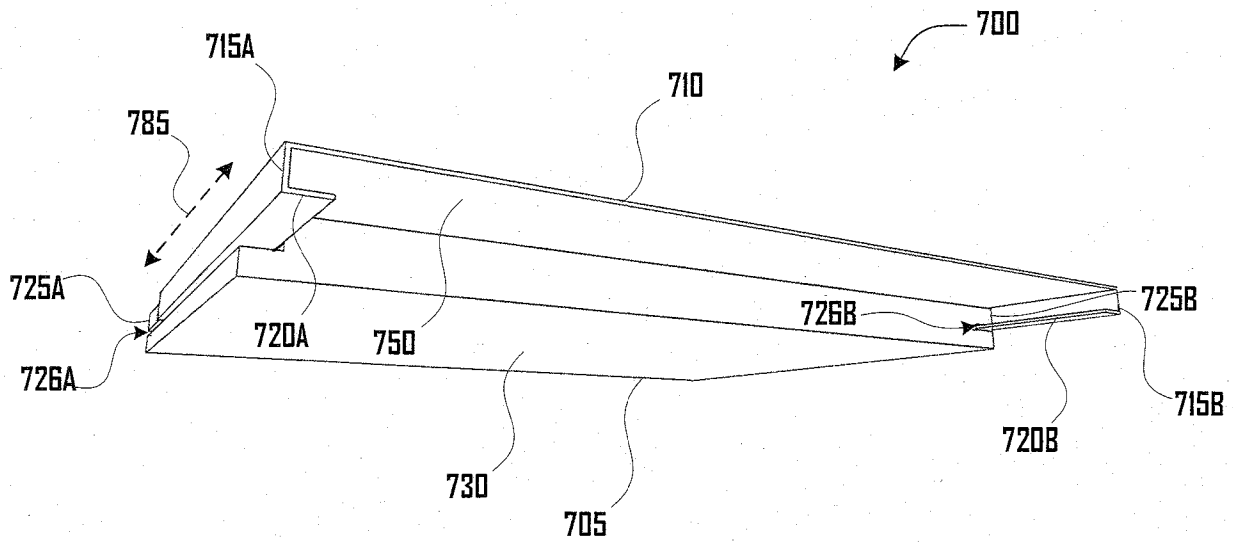

Fig. 7

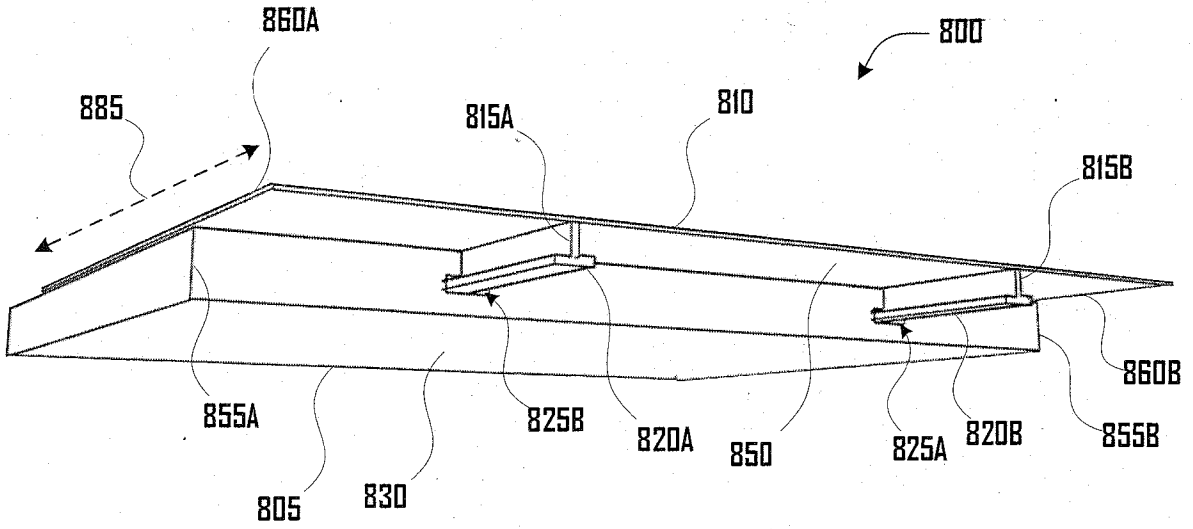

Fig. 8a

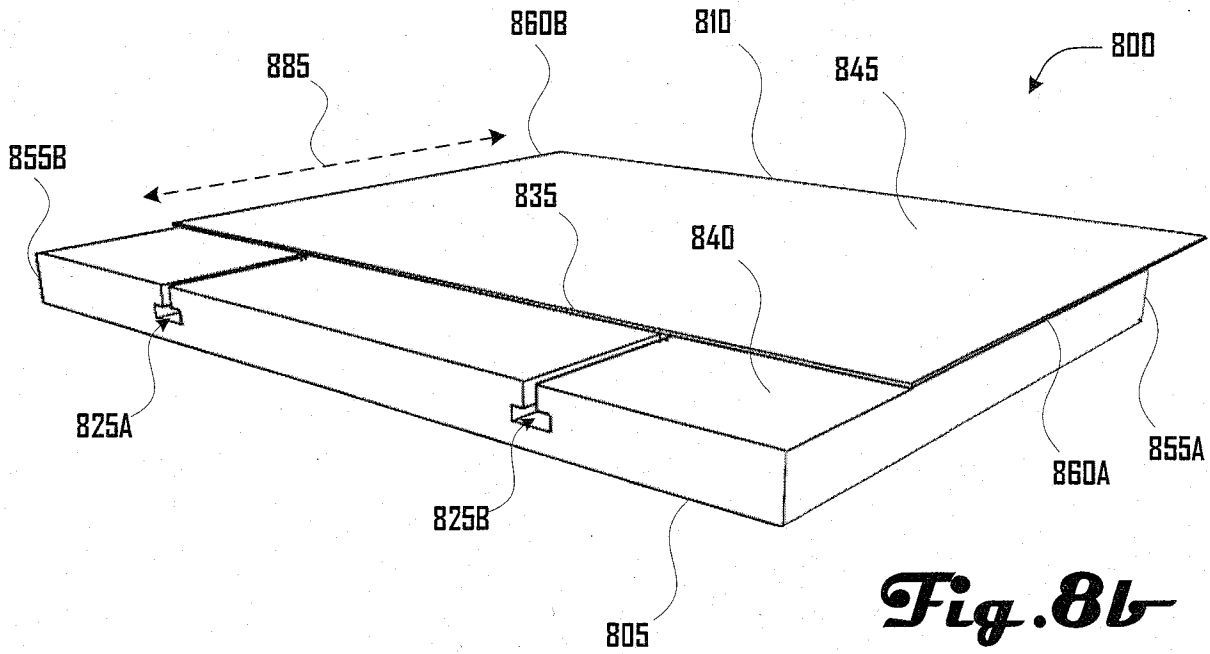

Fig. 8b

8/10

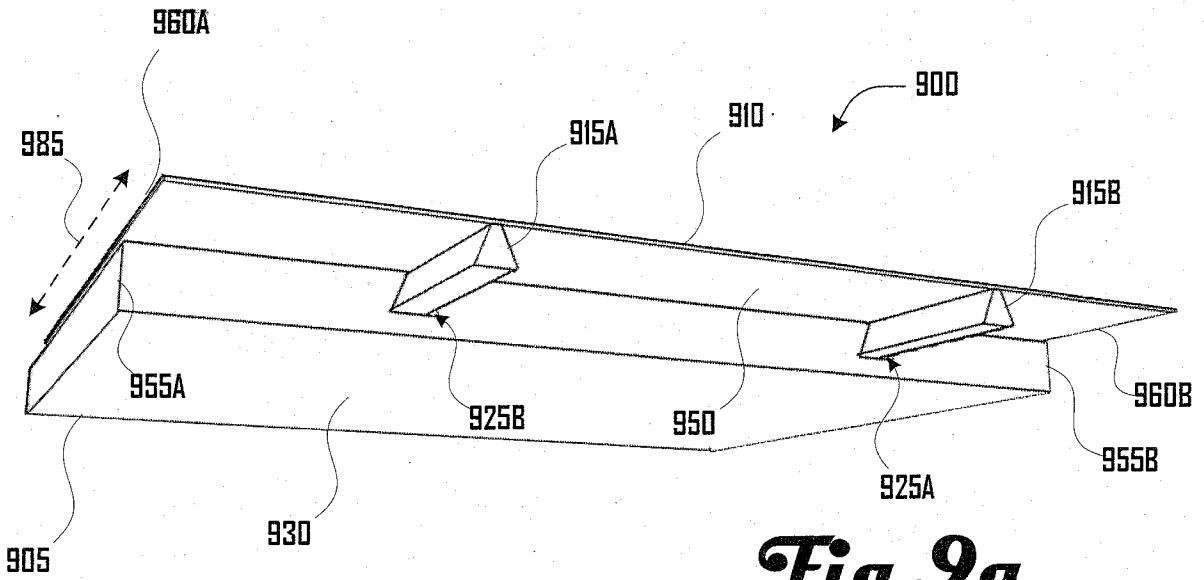

Fig. 9a

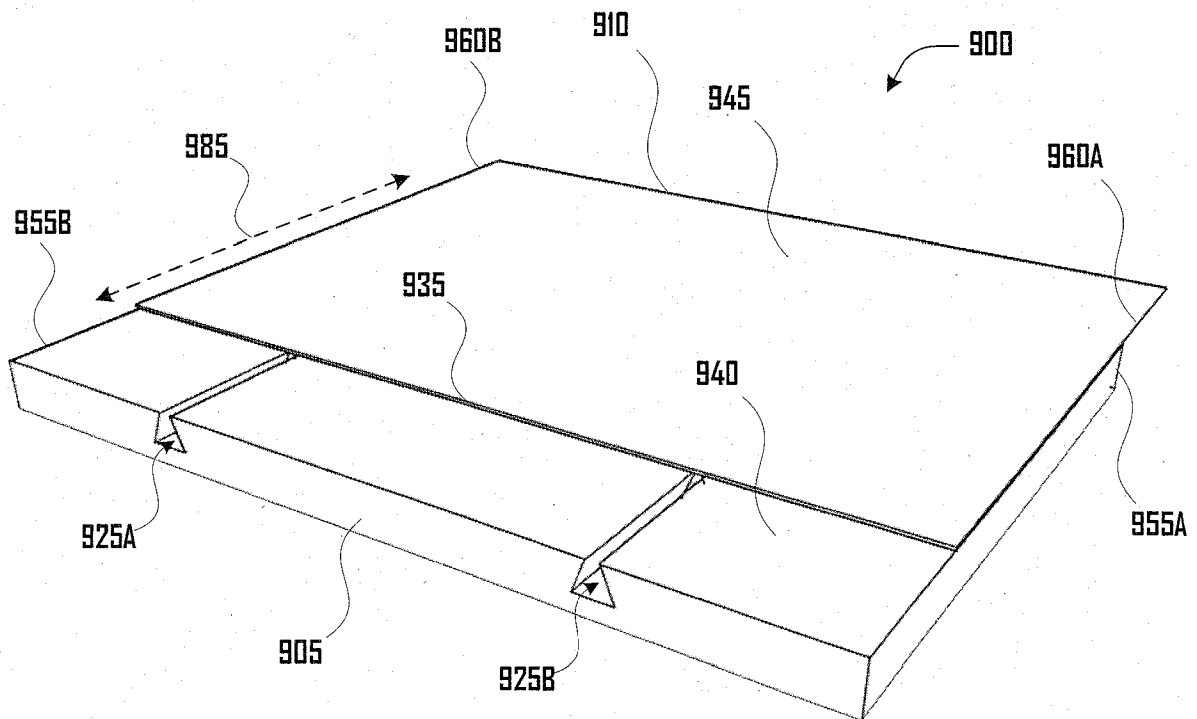

Fig. 9b

9/10

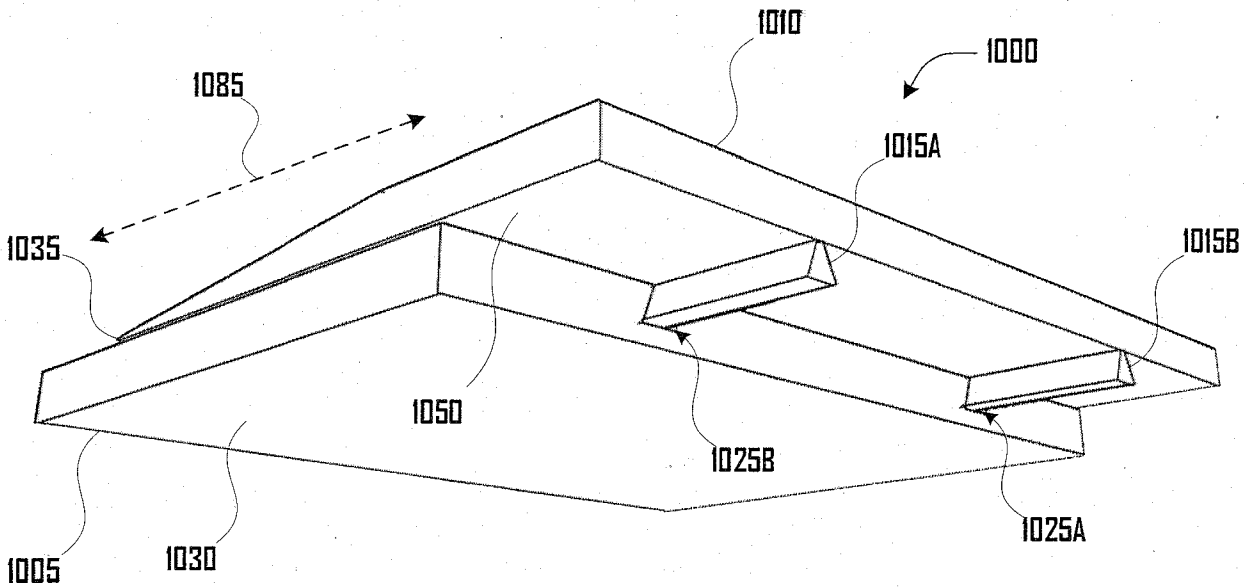

Fig. 10a

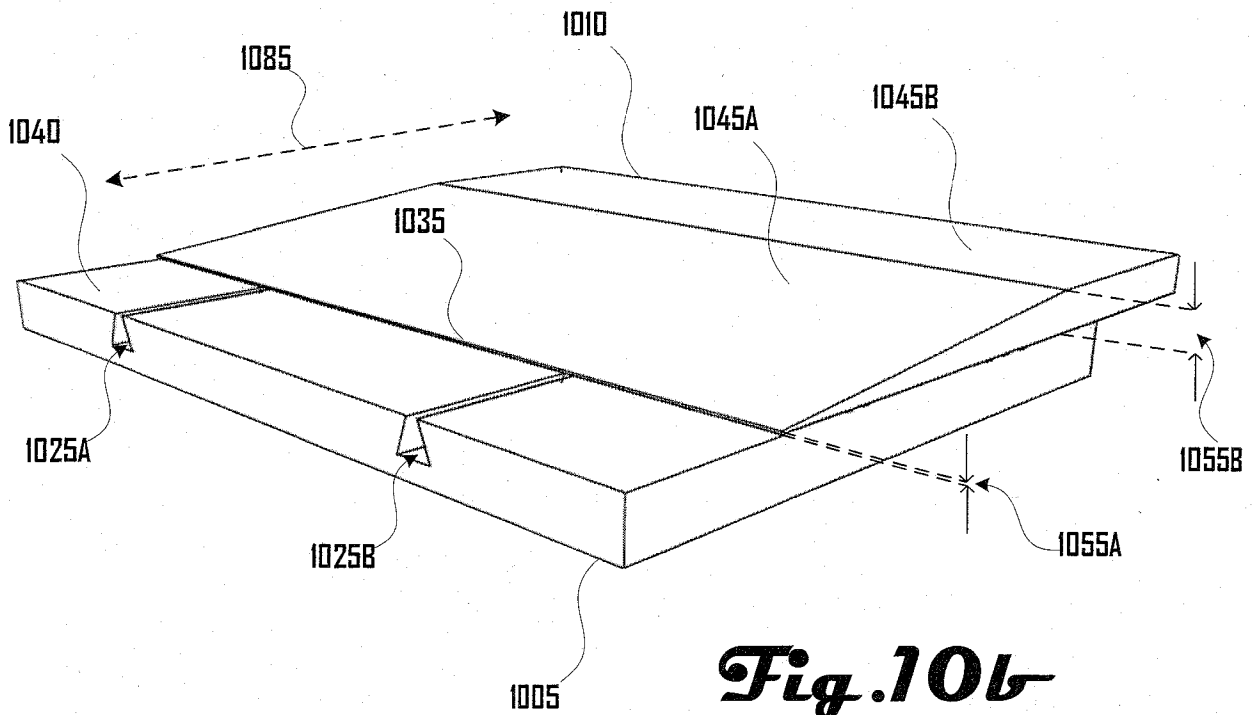

Fig. 10b

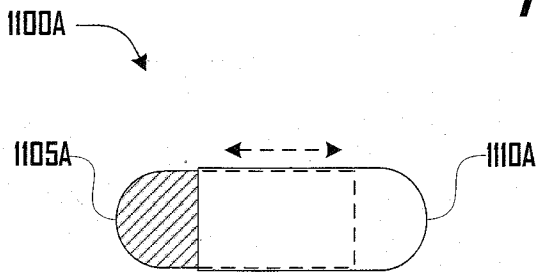

Fig. 11a

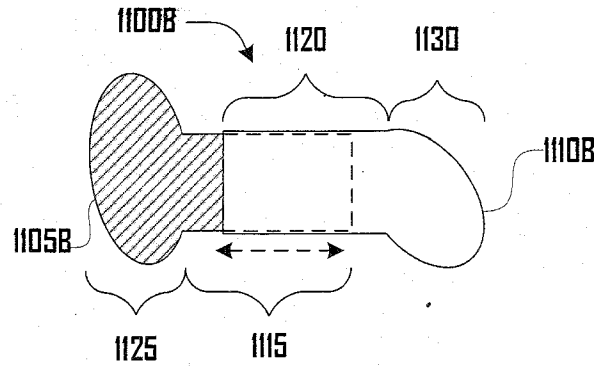

Fig. 11b

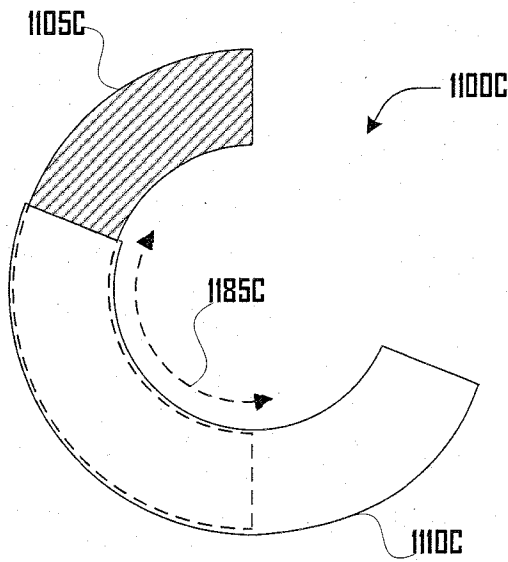

Fig. 11c

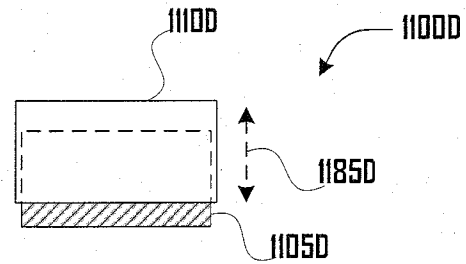

Fig. 11d

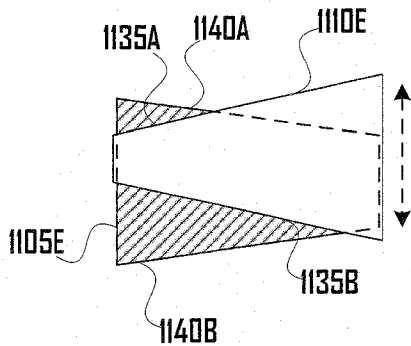

Fig. 11e

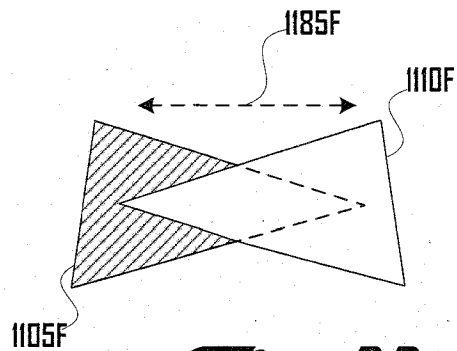

Fig. 11f