

**PATENT ASSIGNMENT**

Electronic Version v1.1  
 Stylesheet Version v1.1

<b>SUBMISSION TYPE:</b>	NEW ASSIGNMENT						
<b>NATURE OF CONVEYANCE:</b>	ASSIGNMENT						
<b>CONVEYING PARTY DATA</b>							
<table border="1" style="width:100%; border-collapse: collapse;"> <thead> <tr> <th style="width:70%;">Name</th> <th>Execution Date</th> </tr> </thead> <tbody> <tr> <td>Lubes Unlimited, Inc.</td> <td>03/08/2010</td> </tr> <tr> <td>Mr. Jon G Mayer</td> <td>03/08/2010</td> </tr> </tbody> </table>		Name	Execution Date	Lubes Unlimited, Inc.	03/08/2010	Mr. Jon G Mayer	03/08/2010
Name	Execution Date						
Lubes Unlimited, Inc.	03/08/2010						
Mr. Jon G Mayer	03/08/2010						
<b>RECEIVING PARTY DATA</b>							
<b>Name:</b>	Flagship Bank Minnesota						
<b>Street Address:</b>	445 East Lake Street						
<b>Internal Address:</b>	Ste. 110						
<b>City:</b>	Wayzata						
<b>State/Country:</b>	MINNESOTA						
<b>Postal Code:</b>	55391						
<b>PROPERTY NUMBERS Total: 1</b>							
<table border="1" style="width:100%; border-collapse: collapse;"> <thead> <tr> <th style="width:30%;">Property Type</th> <th>Number</th> </tr> </thead> <tbody> <tr> <td>Patent Number:</td> <td>6240963</td> </tr> </tbody> </table>		Property Type	Number	Patent Number:	6240963		
Property Type	Number						
Patent Number:	6240963						
<b>CORRESPONDENCE DATA</b>							
<b>Fax Number:</b>	(952)476-4447						
<i>Correspondence will be sent via US Mail when the fax attempt is unsuccessful.</i>							
<b>Email:</b>	gwoodford@wayzatalawgroup.com						
<b>Correspondent Name:</b>	Gregory E. Woodford						
<b>Address Line 1:</b>	1907 E. Wayzata Blvd.						
<b>Address Line 2:</b>	Ste. 170						
<b>Address Line 4:</b>	Wayzata, MINNESOTA 55391						
<b>NAME OF SUBMITTER:</b>	Gregory E. Woodford						
<p><b>Total Attachments: 14</b>          source=Assignment of FDP Patent#page1.tif          source=Assignment of FDP Patent#page2.tif          source=Assignment of FDP Patent#page3.tif          source=Assignment of FDP Patent#page4.tif</p>							

OP \$40.00 6240963

**501304480**

**PATENT  
 REEL: 025051 FRAME: 0592**

source=PATENT - 6240963\_Roll\_off\_self\_powered\_fuel\_dispe1#page1.tif  
source=PATENT - 6240963\_Roll\_off\_self\_powered\_fuel\_dispe1#page2.tif  
source=PATENT - 6240963\_Roll\_off\_self\_powered\_fuel\_dispe1#page3.tif  
source=PATENT - 6240963\_Roll\_off\_self\_powered\_fuel\_dispe1#page4.tif  
source=PATENT - 6240963\_Roll\_off\_self\_powered\_fuel\_dispe1#page5.tif  
source=PATENT - 6240963\_Roll\_off\_self\_powered\_fuel\_dispe1#page6.tif  
source=PATENT - 6240963\_Roll\_off\_self\_powered\_fuel\_dispe1#page7.tif  
source=PATENT - 6240963\_Roll\_off\_self\_powered\_fuel\_dispe1#page8.tif  
source=PATENT - 6240963\_Roll\_off\_self\_powered\_fuel\_dispe1#page9.tif  
source=PATENT - 6240963\_Roll\_off\_self\_powered\_fuel\_dispe1#page10.tif

ASSIGNMENT

PATENT U.S. SERIAL NUMBER 6,240,963 B1 FILED JUNE 5, 2001

WHEREAS, Jon Graham Mayer, Wayzata, Minnesota ("Applicant") has invented a new Roll-off Self-powered Fuel Dispensing Platform System ("Invention"), for which the following Patent application in the United States Patent and Trademark Office was filed: U.S. Serial Number 6,240,963 B1 filed June 5, 2001;

WHEREAS, Applicant assigned the Patent with U.S. Serial Number 6,240,963 B1 filed June 5, 2001 to Lubes Unlimited, Inc., Long Lake, Minnesota ("Assignee"); and,

WHEREAS, Flagship Bank Minnesota, d/b/a Flagship Bank, a Corporation organized and existing under the laws of the State of Minnesota, and having an office and place of business at 445 E Lake Street, Wayzata, Minnesota, 55391, ("Flagship") desires to acquire full ownership and rights in same;

Now, therefore, for good and valuable consideration, the receipt of which Flagship acknowledges, Inventor and Assignee assign to Flagship our full and exclusive ownership and rights to the Invention, and the Patent, and to any Patent U.S. Serial Number 6,240,963 B1 filed June 5, 2001.

We authorize and request the Commissioner of Patent and Trademarks to issue any United States Patent to Flagship, and to give the sole use and benefit of it to Flagship and its legal representatives, until the end of the term for which the Patent may be granted or otherwise entitled to have, as fully and entirely as the same would have been held by us had this Assignment not been made.

This Assignment includes our rights in any provisional, continuation, continuation-in-part, division, reissue, or reexamination application, or any patent that may issue from any such applications, that provides or claims priority from the Patent.

This Assignment includes our rights in any foreign patent application, or any patent that may issue in any foreign jurisdiction from any such application, that claims priority from the Patent.

Applicant and Assignee hereby request the Honorable Commissioner of Patents to issue any Letters Patent which might arise claiming priority from the Patent to Flagship in accordance with this instrument.

Applicant and Assignee further agree, for the consideration aforesaid, that we hereby covenant and agree to and with Flagship, its successors and assigns, that whenever its counsel or the counsel of its successors or assigns, learned in the law, shall advise that any proceeding in connection with the filing or prosecution of said domestic or foreign Patent applications is lawful

and desirable, we, or our executors, administrators or assigns, will sign all papers and drawings, take all rightful oaths, and do all acts necessary or required to be done for the procurement of valid Letters Patent for said Invention, or for the reissue or extension of the same, without charge to Flagship its successors or assigns, but at Flagship's expense.

ASSIGNMENT OF LUBES UNLIMITED, INC.

Title: Roll-off Self-powered Fuel Dispensing Platform System, U.S. Serial Number 6,240,963  
B1 filed June 5, 2001

IN TESTIMONY WHEREOF, on behalf of Lubes Unlimited, Inc., I have hereunto set my hand  
this 8<sup>th</sup> day of March, 2010

Lubes Unlimited, Inc.

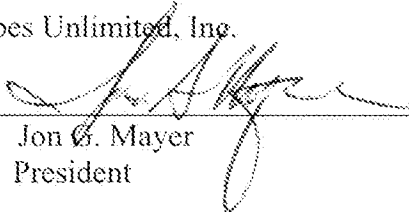
  
\_\_\_\_\_  
By: Jon G. Mayer  
Its: President

Before me personally appeared Jon G. Mayer who acknowledged this instrument to be his free  
act and deed this 8<sup>th</sup> day of March, 2010.

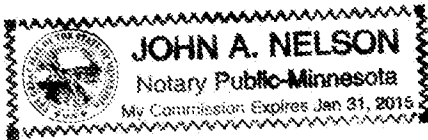

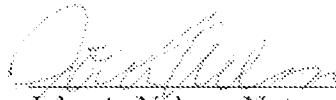
  
\_\_\_\_\_  
John A. Nelson, Notary Public

**ASSIGNMENT OF JON G. MAYER**

Title: Roll-off Self-powered Fuel Dispensing Platform System, U.S. Serial Number 6,240,963  
BI filed June 5, 2001

IN TESTIMONY WHEREOF, I have hereunto set my hand this 8<sup>th</sup> day of March, 2010

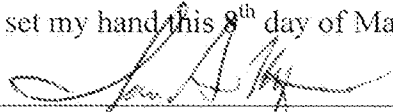
  
\_\_\_\_\_  
Jon G. Mayer

Before me personally appeared Jon G. Mayer who acknowledged this instrument to be his free  
act and deed this 8<sup>th</sup> day of March, 2010.

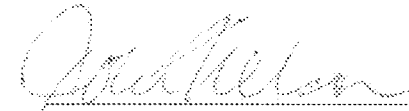
  
\_\_\_\_\_  
John A. Nelson, Notary Public

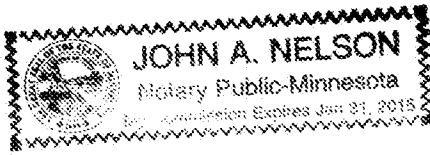



US006240963B1

(12) **United States Patent**  
**Mayer**

(10) **Patent No.:** **US 6,240,963 B1**  
(45) **Date of Patent:** **Jun. 5, 2001**

(54) **ROLL-OFF SELF-POWERED FUEL DISPENSING PLATFORM SYSTEM**

(75) Inventor: **Jon Graham Mayer**, Wayzata, MN (US)

(73) Assignee: **Lubes Unlimited, Inc.**, Long Lake, MN (US)

(\*) Notice: Subject to any disclaimer, the term of this patent is extended or adjusted under 35 U.S.C. 154(b) by 0 days.

(21) Appl. No.: **09/436,299**

(22) Filed: **Nov. 8, 1999**

(51) Int. Cl.<sup>7</sup> ..... **A01G 25/09**

(52) U.S. Cl. .... **137/899**; 137/899.4; 137/355.12; 280/838; 417/361

(58) **Field of Search** ..... 137/899, 899.4, 137/355.12; 280/838; 417/361, 423.1, 423.16, 360

(56) **References Cited**

**U.S. PATENT DOCUMENTS**

4,430,028	*	2/1984	Clayton et al.	406/39
4,708,179	*	11/1987	Beaty	141/388
4,774,979	*	10/1988	McKeon et al.	137/351
4,828,033	*	5/1989	Frison	166/307
4,976,278	*	12/1990	Ripley et al.	137/15
5,052,443	*	10/1991	Evangelist, Jr.	137/899
5,577,772	*	11/1996	Kaiser	280/838
5,577,895	*	11/1996	Franklin et al.	417/238
5,692,884	*	12/1997	Allen et al.	417/361

\* cited by examiner

*Primary Examiner*—A. Michael Chambers  
*Assistant Examiner*—Thomas L. McShane  
(74) *Attorney, Agent, or Firm*—Hugh D. Jaeger

(57) **ABSTRACT**

A roll-off self-powered fuel dispensing platform system which is transportable, deployable, and made operable by a single individual, from a vehicle such as a truck and which includes a roll-off platform assembly, a roller assembly, and a large planar base. A plurality of essential and sensitive components including a fuel vessel, a fuel pumping and metering unit, a pivotally collapsible gravity operated fuel distribution hose support, a fuel distribution hose having a fuel nozzle, and an area lighting apparatus including a pivotally collapsible light standard and a light are mounted on the large planar base. These essential and sensitive components are all confined within a security fence which is mounted on the large planar base around the perimeter thereof. The security fence includes front and side access doors or gates. Located outside the security fence along one side thereof is a pivotable arm assembly which at one end carries a generator platform that extends beneath the front access door or gate of the security fence and into the area confined by the security fence when the roll-off self-powered fuel dispensing platform system is in its transport or storage mode. The generator platform supports an electric generator and a fire extinguisher. Upon opening the front access door or gate, the pivotable arm assembly is movable to relocate the electric generator and the fire extinguisher from within the security fence to a position outside the security fence at a distance away from the fuel vessel and the fuel pumping and metering unit for the operation mode to promote safety during operation.

**13 Claims, 5 Drawing Sheets**

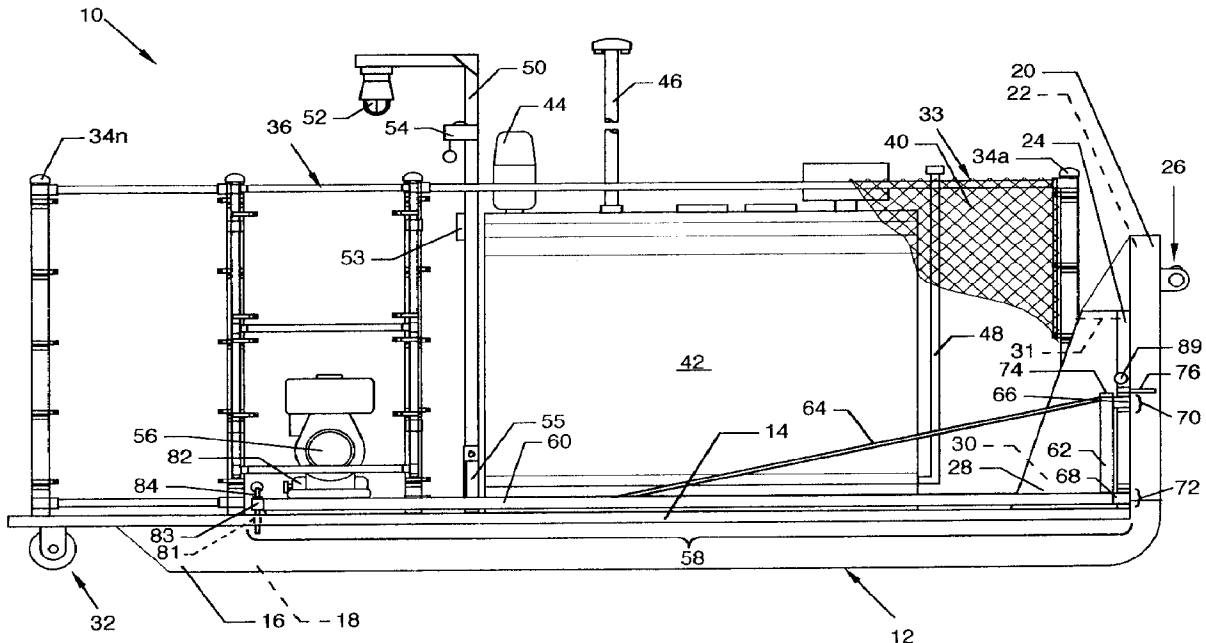





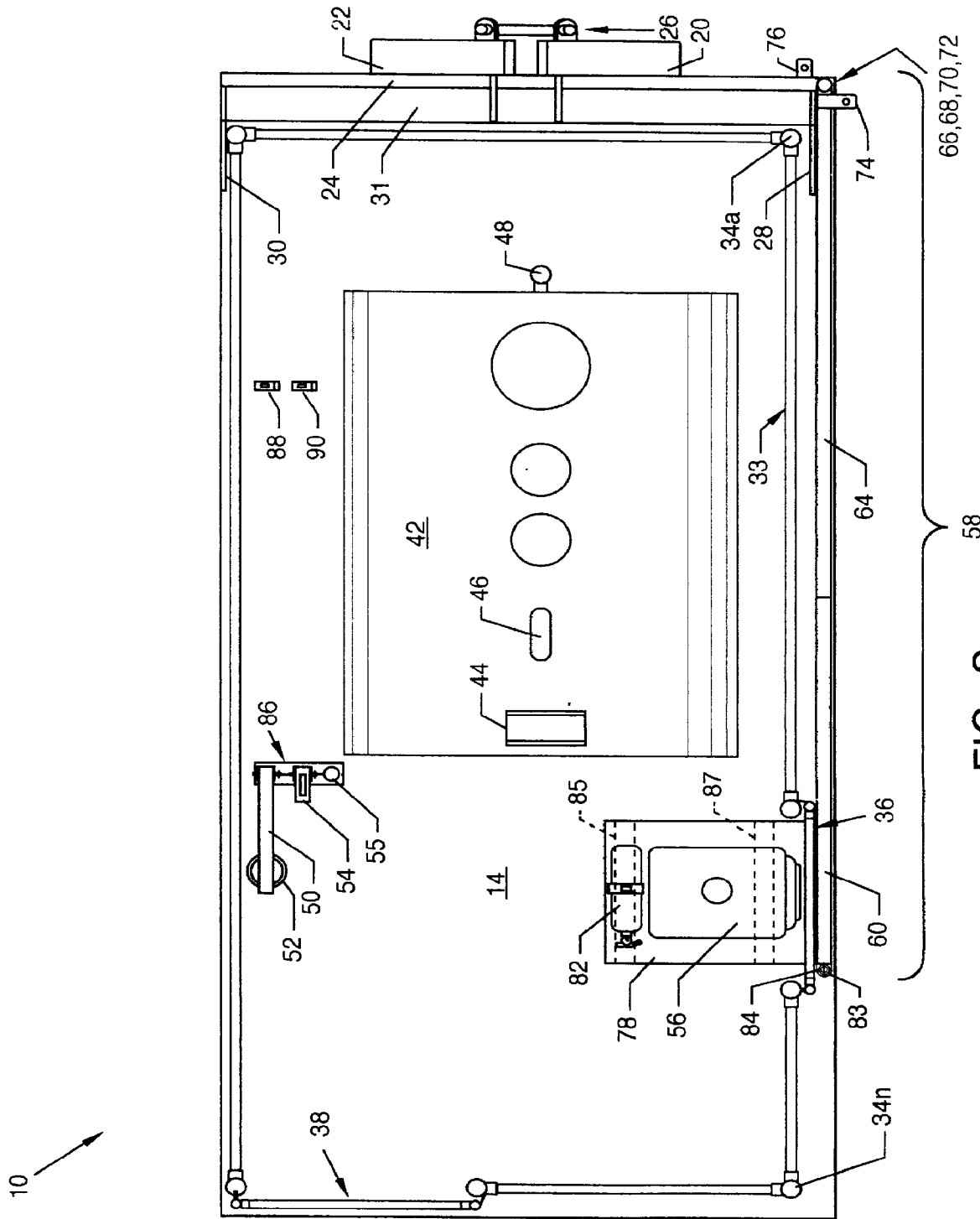

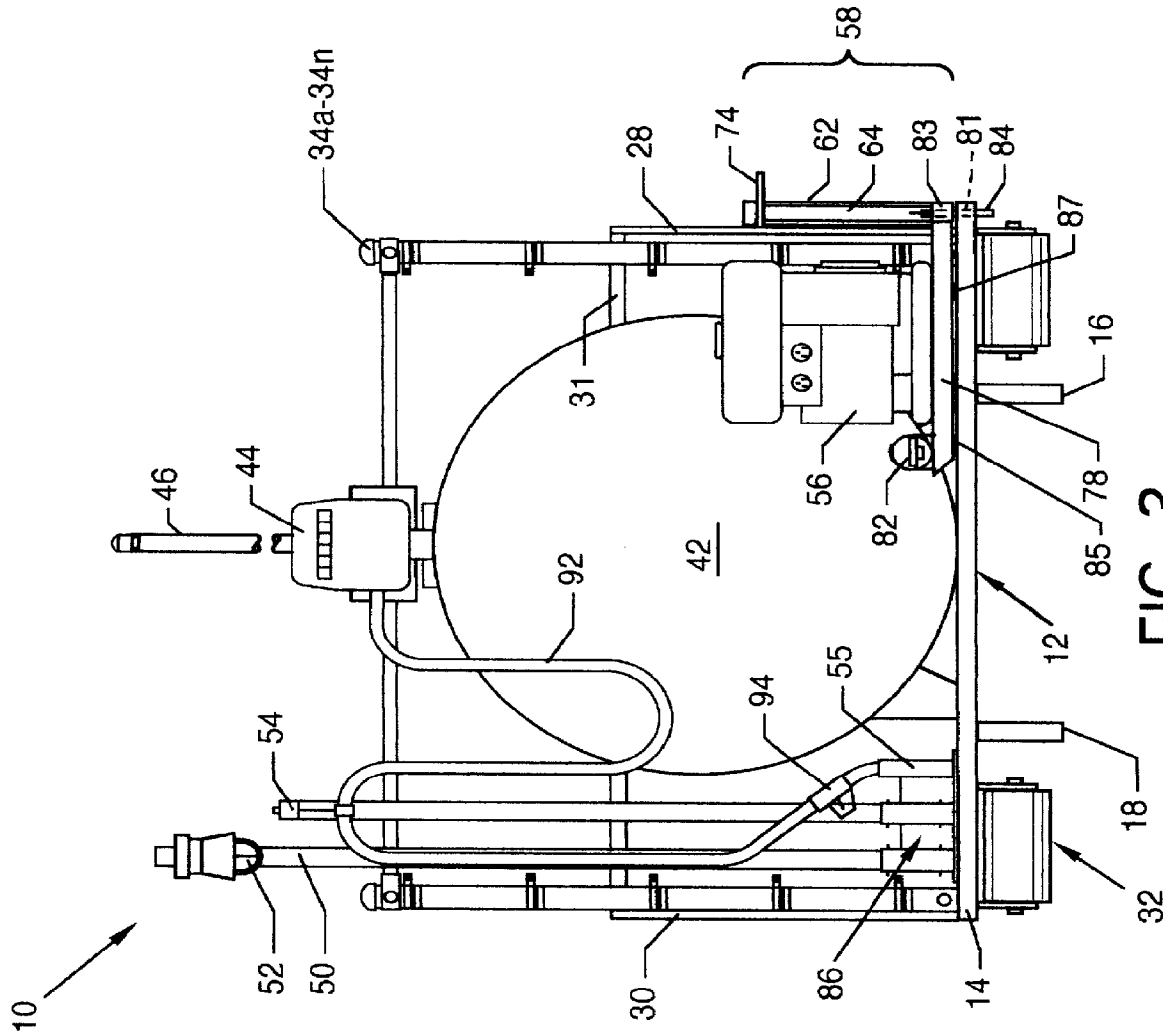

FIG. 3

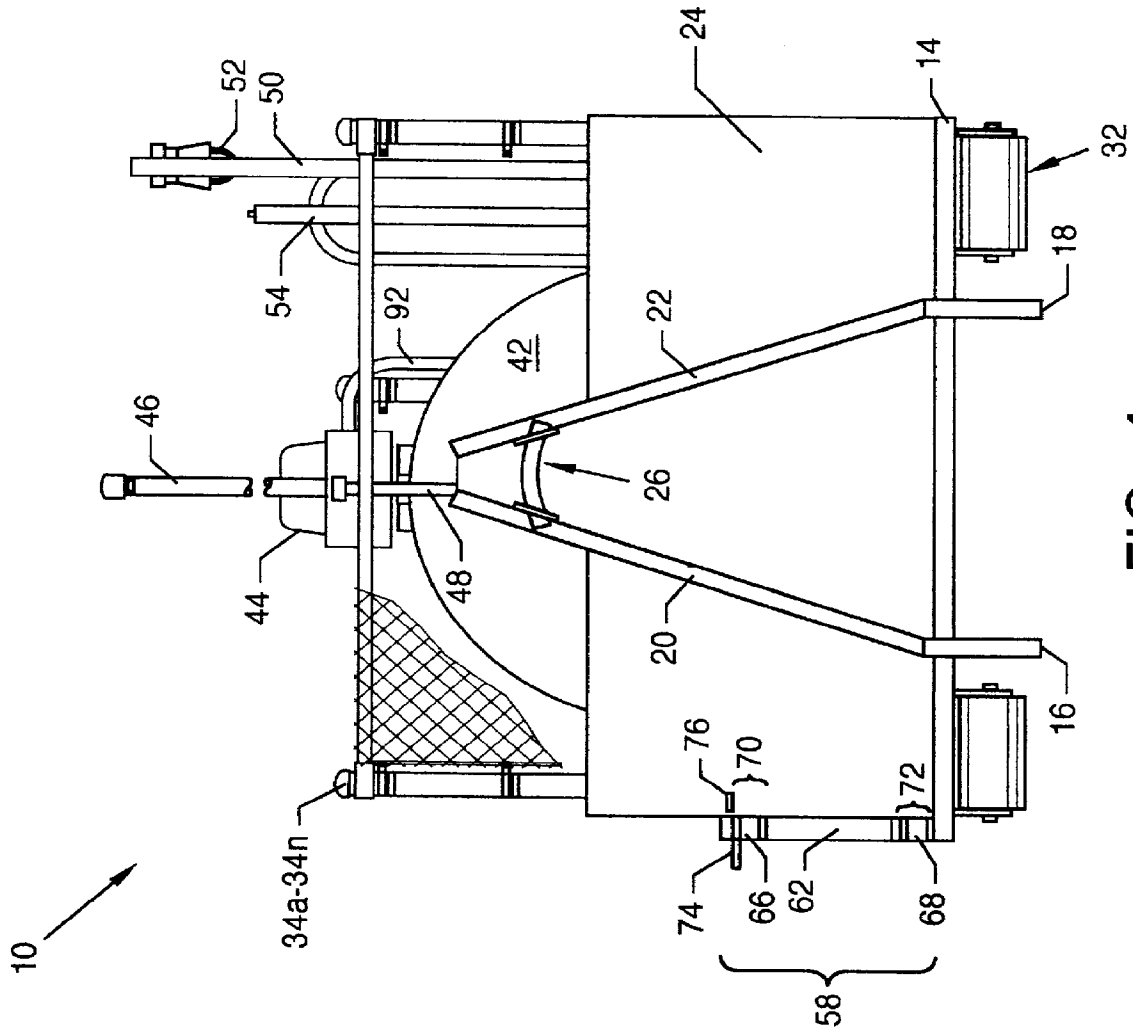

FIG. 4

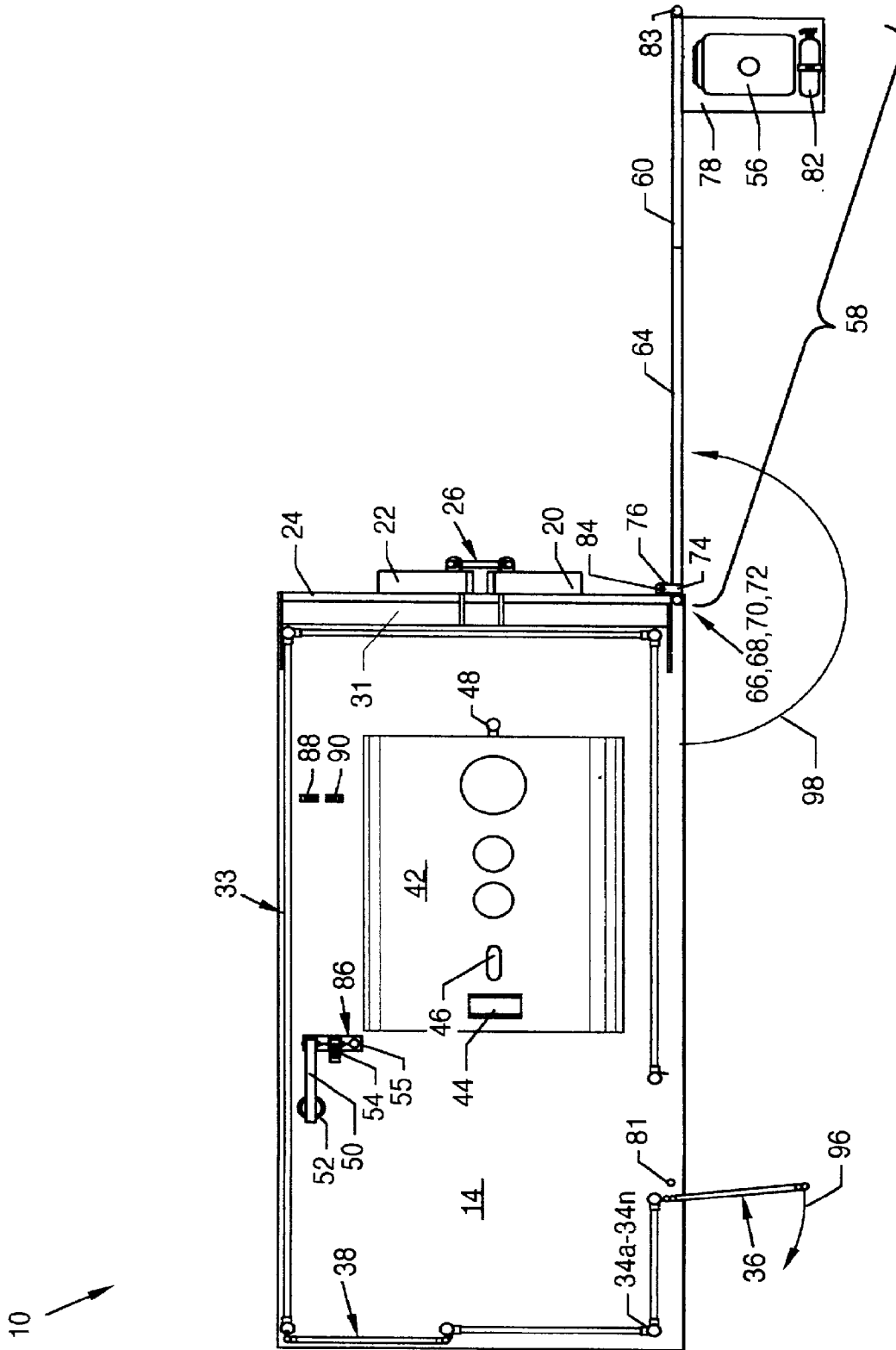

FIG. 5

1

**ROLL-OFF SELF-POWERED FUEL  
DISPENSING PLATFORM SYSTEM****CROSS REFERENCES TO CO-PENDING  
APPLICATIONS**

None.

**BACKGROUND OF THE INVENTION**

## 1. Field of the Invention

The present invention is for a roll-off self-powered fuel dispensing platform system which functions as a portable self-powered fuel dispenser, and in particular is for a roll-off self-powered fuel dispensing platform system which is operated and placed by a single operator, which is transportable upon and deployable from a vehicle such as a truck or other appropriately configured transport device, and which has an electrical power source that is pivotally relocatable at a safe distance from a fuel vessel and a fuel pumping and metering unit.

## 2. Description of the Prior Art

None.

**SUMMARY OF THE INVENTION**

The general purpose of the present invention is to provide a roll-off self-powered fuel dispensing platform system. The roll-off self-powered fuel dispensing platform system includes a roll-off platform assembly having a rectangular base upon which a fuel vessel, a fuel pumping and metering unit, an area lighting apparatus, a fire extinguisher and an electric generator mounted on a pivotable arm assembly, and other components are mounted. For safety and for fire or other codes, it is desirable to have the fuel vessel and the fuel pumping and metering unit located at a distance from any sources which could promote fire or explosion such as, but not limited to, the electric generator and its exhaust system. The pivotable arm assembly provides a means for easily and readily moving the electric generator to a location distant from the fuel vessel and the fuel pumping and metering unit prior to starting of the generator and use of the fuel pumping and metering unit. The area lighting apparatus includes a pivotally collapsible light standard and a light for illumination for use of the invention at night; and a security fence is provided to deter theft and vandalism of essential and sensitive components of the invention. The roll-off self-powered fuel dispensing platform system can be delivered, deployed and operated by a single operator. The invention can also function with electrical power provided by another external and outside source if nearby electrical power is available for use and if the electrical generator is not required or desired.

According to one embodiment of the present invention, there is provided a roll-off self-powered fuel dispensing platform system including a roll-off platform assembly and such elements as a security fence including access doors or gates, a pivotally collapsible light standard and a light, a pivotally collapsible gravity operated fuel distribution hose support, a fuel vessel, a fuel pumping and metering unit, and a pivotable arm assembly, all of which secure to the base the roll-off platform or ending of and comprise the majority of the members of the roll-off platform assembly. An electric generator and a fire extinguisher are secured to a generator platform located on one end of the pivotable arm assembly.

One significant aspect and feature of the present invention is a roll-off self-powered fuel dispensing platform system which is portable, self-powered and self-contained.

2

Another significant aspect and feature of the present invention is a roll-off self-powered fuel dispensing platform system which includes a fuel vessel, a fuel pumping and metering unit, and an electric generator mounted to the base of a roll-off platform assembly, with the electric generator being mounted on a pivotable arm assembly which is moveable to distance and locate the electric generator away from the fuel vessel and the fuel pumping and metering unit prior to operation.

Still another significant aspect and feature of the present invention is an area lighting apparatus for operation of the invention at night.

Yet another significant aspect and feature of the present invention is a security fence surrounding the inwardly located essential and sensitive components of the invention.

A further significant aspect and feature of the present invention is a roll-off self-powered fuel dispensing platform system which can be delivered, deployed from a vehicle and set up by a single operator.

Having thus described embodiments and significant aspects and features of the present invention, it is the principal object of the present invention to provide a roll-off self-powered fuel dispensing platform system.

**BRIEF DESCRIPTION OF THE DRAWINGS**

Other objects of the present invention and many of the attendant advantages of the present invention will be readily appreciated as the same becomes better understood by reference to the following detailed description when considered in connection with the accompanying drawings, in which like reference numerals designate like parts throughout the figures thereof and wherein:

FIG. 1 illustrates a front view of a roll-off self-powered fuel dispensing platform system, the present invention;

FIG. 2 illustrates a top view of the roll-off self-powered fuel dispensing platform system;

FIG. 3 illustrates a left end view of the roll-off self-powered fuel dispensing platform system with various fencing and door or gate components not shown;

FIG. 4 illustrates a right end view of the roll-off self-powered fuel dispensing platform system with various fencing and door or gate components not shown; and,

FIG. 5 illustrates the mode of operation of the roll-off self-powered fuel dispensing platform system with the electric generator distanced from the centrally located components by the pivotable arm assembly.

**DETAILED DESCRIPTION OF THE  
PREFERRED EMBODIMENTS**

FIG. 1 illustrates a front view of a roll-off self-powered fuel dispensing platform system 10. A plurality of components secure to a suitable portable and mobile structure, which in this case is a roll-off platform assembly 12 such as that which is transportable upon and deployable from a truck or other vehicle. Although a roll-off platform assembly 12, such as normally used with roll-off devices, is exemplified as the suitable portable and mobile structure, other suitable portable and mobile structures such as a truck bed, a rail car flat bed or other such structure which can be readily transported can be utilized as a suitable structure, and therefore the use of a roll-off platform assembly 12 shall not be deemed to be limiting to the scope of the invention. The roll-off platform assembly 12 includes a large planar base 14, skids 16 and 18 secured and distributed horizontally along the bottom of the base 14, upwardly and inwardly

extending box tubes **20** and **22** secured to one end of the skids **16** and **18** and to a vertically oriented support plate **24** mounted on the base **14**, a forward hooking assembly **26** secured to the box tubes **20** and **22** for use in pulling or otherwise transporting the roll-off platform assembly **12**, vertically aligned support plates **28** and **30** secured between the support plate **24** and the base **14**, a support plate **31** located between the tops of the support plates **24**, **28**, **30**, and a roller assembly **32** including a plurality of rollers secured to the bottom of the base **14**. A security fence **33** mounted on the base **14** surrounds the essential and sensitive components of the roll-off self-powered fuel dispensing platform system **10**. The security fence **33** is located at the perimeter of the base **14** and includes a plurality of standards **34a-34n** including fence support structure secured to the base **14**, a front access door or gate **36**, a side access door or gate **38** (FIG. 2), and woven wire mesh **40** (only partially shown) appropriately located and supported between the standards **34a-34n** and the fence support structure. Woven wire mesh **40** also spans the access doors or gate **36** and **38**. Some of the essential and sensitive components include a fuel vessel or fuel tank **42** secured to the base **14**, a fuel pumping and metering unit **44**, (i.e., a pump and meter combination) a fuel distribution hose **92** (FIG. 3), a readily and easily removable vent **46**, and a filler tube **48**. Other essential and sensitive components viewable in FIG. 1 are adjacently located components including a pivotally collapsible light standard **50**, a light **52** and a light switch **53** both of which are explosion proof, a pivotally collapsible gravity operated distribution hose support **54**, and a fuel nozzle support **55**.

With reference to FIGS. 1 and 2, another sensitive component, a means for powering the pump, shown as an electric generator **56**, which also is protected behind the security fence **33**, is now described. The electric generator **56**, when not functioning and for purposes of transport or for protection against theft or vandalism, is housed behind the security fence **33** in general, and more specifically, is located just behind the front access door or gate **36**. A pivotable arm assembly **58** at a forward end is provided for support of the electric generator **56** at all times including storage, transportation, and for distanced support during operation of the electric generator **56** for pumping or other uses. The pivotable arm assembly **58** includes a horizontally oriented pivot arm **60**, a vertically oriented support tube **62** the lower end of which secures to the pivot arm **60**, a support bar **64** secured at one end to the upper region of the support tube **62** and at the other end to a mid portion of the support bar **60**, vertically oriented pivot housings **66** and **68** secured to the upper and lower end regions of the support tube **62**, upper and lower pivot brackets **70** and **72** secured to the support plate **24**, and pivot pins (not illustrated) passing through the pivot housings **66** and **68** and pivot brackets **70** and **72**, respectively, to pivotally connect the pivotable arm assembly **58** to the base **14** via the support plates **24** and **28**. A locking tab **74** having a body hole secures to and extends outwardly towards the viewer from the upper region of the vertical support tube **62** and another locking tab **76** having a body hole extends sideways from the support plate **24**, the uses of which are described later in detail. A generator platform **78**, part of the pivot arm assembly **58**, secures to and extends horizontally and inwardly from the left end of the pivot arm **60**, as also shown in FIG. 3. The generator platform **78** also extends beneath the bottom of the front access door or gate **36**. The electric generator **56** and a fire extinguisher **82** mount to the upper side of the generator platform **78** and are protectively located inwardly from and behind the front access door or gate **36**. A removable pin **84**

extends through a cylindrical sleeve **83** secured to the left end of the pivot arm **60** and through an aligned hole **81** in the base **14** to secure the left end of the pivotable arm assembly **58** from rotation about the pivot structure adjacent to the support tube **62** during periods of transport or storage. The removable pin **84** is also utilized during operation of the invention, as later described in detail. Teflon support bars **85** and **87** shown in dashed lines in FIG. 2 are secured to the bottom of the generator platform **78** to provide for support of the electric generator **56**, the fire extinguisher **82** and the generator platform **78** in intimate contact with the base **14** located at the left end of the pivot arm **60**. Such support is especially desirable during transportation of the roll-off self-powered fuel dispensing platform system **10** to relieve vertical transportation stresses on the pivotal arm assembly **58**. A properly housed (explosion proof) electrical power line (not illustrated) is routed from the electric generator **56** along the pivot arm **60**, upwardly along the support bar **64** and through an orifice **89** (FIG. 1) extending through the support plate **24** to the required areas such as, but not limited to, the light **52** and the fuel pumping and metering unit **44**. The pivotally collapsible light standard **50**, the pivotally collapsible gravity operated fuel distribution hose support **54** and the fuel nozzle support **55** are part of a support assembly **86**, best shown in FIG. 3. The support assembly **86** provides structure for the support of the pivotally collapsible light standard **50** and the pivotally collapsible gravity operated fuel distribution hose support **54**, each of which utilizes a pivot and a locking pin extending through the structure of the support assembly **86**, and for the fuel nozzle support **55**. Clamps **88** and **90** are secured to the base **14** to secure the pivotally collapsible light standard **50** and the pivotally collapsible gravity operated fuel distribution hose support **54**, respectively, in the collapsed position such as for transport of the roll-off self-powered fuel dispensing platform system **10**.

FIG. 3 illustrates a left end view of the roll-off self-powered fuel dispensing platform system **10**, where all numerals correspond to those previously or otherwise described. The security fence woven wire mesh **40** is not shown and several of the standards **34a-34n** and the access doors or gates **36** and **38** are not shown for the purpose of brevity and clarity. Illustrated in particular is the relationship of the pivotable arm assembly **58** to the components of the roll-off platform assembly **12**. In particular, the Teflon support bars **85** and **87** of the generator platform **78**, having the electric generator **56** and the fire extinguisher **82** attached thereto, are shown in intimate relationship with the upper surface of the base **14**.

Also illustrated in FIG. 3 is the fuel distribution hose **92** connecting between the fuel pumping and metering unit **44** and a fuel nozzle **94**. The pivotally collapsible gravity operated fuel distribution hose support **54** supports the fuel distribution hose **92**; and the fuel nozzle **94** is supported by the fuel nozzle support **55** located at one end of the support assembly **86**.

FIG. 4 illustrates a right end view of the roll-off self-powered fuel dispensing platform system **10**, where all numerals correspond to those previously or otherwise described. Shown in particular is the hooking assembly **26** secured to the box tubes **20** and **22**. Also shown in the illustration is the relationship of the locking tab **74** on the support tube **62** to the locking tab **76** extending from the support plate **24**.

#### MODE OF OPERATION

FIGS. 2 and 5 illustrate the mode of operation of the roll-off self-powered fuel dispensing platform system **10**,

where all numerals correspond to those previously or otherwise described. FIG. 2 illustrates, with the exception of the pivotally collapsible light standard 50, the pivotally collapsible gravity operated fuel distribution hose support 54, and the vent 46, the configuration of the roll-off self-powered fuel dispensing platform system 10 in the transport or storage mode. In the transport mode, and in the storage mode if desired, the pivotally collapsible light standard 50 and the pivotally collapsible gravity operated fuel distribution hose support 54 would be pivoted about the support assembly 86 and secured to the base 14 in a substantially horizontal position by the clamps 88 and 90, respectively; and the vent 46 would be removed to present a low profile for vertical clearance during transport. The pivotable arm assembly 58 is secured in a position parallel to and just above the front edge of the base 14 by the pin 84 extending through the cylindrical sleeve 83 at the left end of the pivot arm 60. The majority of the generator platform 78 is subsequently fixed in position inwardly behind the front access door or gate 36, and a portion of the generator platform 78 extends beneath the front access door or gate 36. The electric generator 56 and the fire extinguisher 82 are protectively located on the generator platform 78 behind the front access door or gate 36 which, of course, can include a locking mechanism.

FIG. 5 illustrates the configuration of the roll-off self-powered fuel dispensing platform system 10 for use in the dispensing mode. In the dispensing mode either of the access doors or gates 36 or 38 is used to allow an operator access behind the security fence 33 to erect the pivotally collapsible gravity operated fuel distribution hose support 54, the pivotally collapsible light standard 50, and the vent 46. The access door or gate 36 must first be opened as shown by arrow 96 to allow for pivotal repositioning of the pivotable arm assembly 58 as shown by arrow 98 about the pivot housings 66 and 68 and the pivot brackets 70 and 72. Pivotal repositioning of the pivotable arm assembly 58 is instrumental in transporting the electric generator 56 as well as the fire extinguisher 82 a safe distance from the centrally located components of the invention such as the fuel vessel or fuel tank 42, the fuel pumping and metering unit 44 and other critical components. Subsequent to disengagement of the pin 84 from the hole 81 in the base 14 and from the cylindrical sleeve 83, the pivotable arm assembly 58 is pivotally repositioned as indicated by arrow 98. Pivotal repositioning of the pivotable arm assembly 58 provides for alignment of the locking tab 74 of the pivotable arm assembly 58 with the locking tab 76 located on the support plate 24. The pin 84 is then inserted through the aligned body holes located in the aligned locking tabs 74 and 76 to positionally secure the pivotable arm assembly 58 at a safe distance from the fuel vessel or fuel tank 42, the fuel pumping and metering unit 44 and other critical components. The electric generator 56 can be started at the position shown to be utilized to provide power for the fuel pumping and metering unit 44, the light 52 and other externally located devices as required. Furthermore, during generator operation, the access doors or gates 36 and 38 can be locked closed to deny access to the components such as the fuel pumping and metering unit 44 located inside the security fence 33, if desired.

Various modifications can be made to the present invention without departing from the apparent scope hereof.

ROLL-OFF SELF-POWERED FUEL DISPENSING PLATFORM SYSTEM

PARTS LIST

10	roll-off self-powered fuel dispensing platform system
12	roll-off platform assembly
14	base
16	skid
18	skid
20	box tube
22	box tube
24	support plate
26	hooking assembly
28	support plate
30	support plate
31	support plate
32	roller assembly
33	security fence
34a-n	standards
36	front access door or gate
38	side access door or gate
40	woven wire mesh
42	fuel vessel or fuel tank
44	fuel pumping and metering unit
46	vent
48	filler tube
50	collapsible light standard
52	light
53	light switch
54	collapsible fuel distribution hose support
55	fuel nozzle support
56	electric generator
58	pivotable arm assembly
60	pivot arm
62	support tube
64	support bar
66	pivot housing
68	pivot housing
70	pivot bracket
72	pivot bracket
74	locking tab
76	locking tab
78	generator platform
81	hole
82	fire extinguisher
83	cylindrical sleeve
84	pin
85	support bar
86	support assembly
87	support bar
88	clamp
89	orifice
90	clamp
92	fuel distribution hose
94	fuel nozzle
96	arrow
98	arrow

What is claimed is:

1. A roll-off self-powered fuel dispensing platform system comprising:
  - a. a roll-off platform assembly means;
  - b. said roll-off platform assembly means including a fuel tank;
  - c. a pump connected to said fuel tank for pumping fuel from said fuel tank;
  - d. said roll-off platform assembly means including a pivot means on a forward end thereof;
  - e. an arm means with a means to power said pump mounted on said pivot means, said arm means being pivotable from a first position whereat said means to power said pump is located adjacent to said fuel tank

7

and pump to a use position whereat said means to power said pump is located away from said fuel tank and pump, thereby distancing said means to power said pump from said fuel tank and pump.

2. The system of claim 1, whereby said roll-off platform assembly means includes a fence means around said fuel tank and pump.

3. The system of claim 2, wherein said fence means includes a gate.

4. The system of claim 1, whereby said roll-off platform assembly means includes a light pole means.

5. A roll-off self-powered fuel dispensing platform system, comprising: a roll-off platform assembly including a base on which is mounted a fuel tank, a pump connected to said fuel tank for pumping fuel from said fuel tank, and a pivotable arm assembly supporting a generator for powering said pump; said pivotable arm assembly being pivotable from a first position at which said generator is located near to said fuel tank and pump to a second position at which said generator is located far from said fuel tank and pump.

6. The system of claim 5, wherein said roll-off platform assembly further includes a fence mounted on said base, said fence surrounding said fuel tank and said pump.

7. The system of claim 6, wherein said pivotable arm assembly is located outside said fence and has a first end

8

which is pivotally attached to said base and a second end to which is attached a platform that extends beneath said fence from outside said fence to inside said fence such that a portion of said platform resides outside said fence and a portion of said platform resides inside said fence, the portion of said platform which resides inside said fence supporting said generator.

8. The system of claim 7, wherein said fence includes a gate at the position at which said platform extends therebeneath.

9. The system of claim 6, wherein said roll-off platform assembly further includes an area lighting apparatus mounted on said base inside said fence.

10. The system of claim 5, wherein said generator is an electric generator.

11. The system of claim 5, wherein a meter is associated with said pump.

12. The system of claim 5, wherein said roll-off platform assembly further includes a forward hooking assembly for use in pulling or otherwise transporting.

13. The system of claim 5, wherein said pump includes a fuel distribution hose having a nozzle.

\* \* \* \* \*