

## PATENT ASSIGNMENT COVER SHEET

Electronic Version v1.1  
Stylesheet Version v1.2

EPAS ID: PAT3281832

<b>SUBMISSION TYPE:</b>	NEW ASSIGNMENT
<b>NATURE OF CONVEYANCE:</b>	ASSIGNMENT
<b>CONVEYING PARTY DATA</b>	
<b>Name</b>	<b>Execution Date</b>
GARRETT K. W. PARKER	12/12/2012
<b>RECEIVING PARTY DATA</b>	
<b>Name:</b>	SAMSONITE LLC
<b>Street Address:</b>	575 WEST STREET, SUITE 110
<b>City:</b>	MANSFIELD
<b>State/Country:</b>	MASSACHUSETTS
<b>Postal Code:</b>	02048
<b>PROPERTY NUMBERS Total: 1</b>	
<b>Property Type</b>	<b>Number</b>
<b>Application Number:</b>	29515658
<b>CORRESPONDENCE DATA</b>	
<b>Fax Number:</b>	(303)629-3450
<i>Correspondence will be sent to the e-mail address first; if that is unsuccessful, it will be sent using a fax number, if provided; if that is unsuccessful, it will be sent via US Mail.</i>	
<b>Phone:</b>	(303) 629-3400
<b>Email:</b>	sawatzke.ginny@dorsey.com
<b>Correspondent Name:</b>	LEE R. OSMAN/DORSEY & WHITNEY LLP
<b>Address Line 1:</b>	1400 WEWATTA STREET, SUITE 400
<b>Address Line 4:</b>	DENVER, COLORADO 80202
<b>ATTORNEY DOCKET NUMBER:</b>	P236074.US.04
<b>NAME OF SUBMITTER:</b>	GINNY SAWATZKE F/B/O LEE R. OSMAN
<b>SIGNATURE:</b>	/Ginny Sawatzke F/B/O Lee R. Osman/
<b>DATE SIGNED:</b>	03/25/2015
<b>Total Attachments: 12</b>	
source=P236074.US.04_AssignmentFromGParkertoSamsoniteLLC_#page1.tif	
source=P236074.US.04_AssignmentFromGParkertoSamsoniteLLC_#page2.tif	
source=P236074.US.04_AssignmentFromGParkertoSamsoniteLLC_#page3.tif	
source=P236074.US.04_AssignmentFromGParkertoSamsoniteLLC_#page4.tif	
source=P236074.US.04_AssignmentFromGParkertoSamsoniteLLC_#page5.tif	
source=P236074.US.04_AssignmentFromGParkertoSamsoniteLLC_#page6.tif	

source=P236074.US.04\_AssignmentFromGParkertoSamsoniteLLC\_#page7.tif  
source=P236074.US.04\_AssignmentFromGParkertoSamsoniteLLC\_#page8.tif  
source=P236074.US.04\_AssignmentFromGParkertoSamsoniteLLC\_#page9.tif  
source=P236074.US.04\_AssignmentFromGParkertoSamsoniteLLC\_#page10.tif  
source=P236074.US.04\_AssignmentFromGParkertoSamsoniteLLC\_#page11.tif  
source=P236074.US.04\_AssignmentFromGParkertoSamsoniteLLC\_#page12.tif

**ASSIGNMENT**

WHEREAS, I, Garrett K. W. Parker, residing at 159 Bay View Avenue, Berkley, Massachusetts 02779 U.S.A. (hereinafter, individually and collectively the "Assignor"), have conceived of a certain original and ornamental design as represented in the attached Samsonite Request For Design Patent To Be Filed having the product line name AT ball wheel (the "Design"); and

WHEREAS, Assignor desires to assign any and all right, title and interest to said Design, and any continuation, continuation-in-part, divisional, international, foreign, regional and convention applications corresponding thereto, and any and all design registrations and Design Letters Patent of the Office For Harmonization in the Internal Market ("OHIM"), United States, and countries and regions foreign thereto which may grant or have granted thereto or be lodged in relation thereto, any reissue or reexamination thereof or to be obtained therefor, any renewals, or substitutes thereof, and any and all priority rights or priority claims, International Convention rights, any and all rights to collect past damages for infringement of any and all design registrations and Letters Patent of the OHIM, United States, and countries and regions foreign thereto which may be published, which may grant, or have granted thereto or be lodged in relation thereto, and other benefits accruing to or to accrue to Assignor with respect to the filing of applications for patents or securing of patents in the OHIM, United States, and countries foreign thereto (the "Patent Rights");

WHEREAS, Samsonite LLC, 575 West Street, Suite 110, Mansfield, Massachusetts 02048 U.S.A. (the "Assignee"), desires to acquire any and all, right, title, and interest of Assignor in and to the design(s), the Design, the Patent Rights, and in, to, and under any and all design registrations and Design Letters Patent to be obtained therefor.

NOW THEREFORE, for the sum of \$1.00 and other good and valuable consideration to Assignor in hand paid, the receipt and sufficiency of which are hereby acknowledged, Assignor has sold, assigned, and transferred and by these presents does hereby sell, assign and transfer to the said Assignee, and said Assignee's legal representatives, successors and assigns, any and all of the entire right, title and interest in and to the Design, Patent Rights, and any and all design registrations and Design Letters Patent to be obtained therefor;

UPON SAID CONSIDERATION, the Assignor hereby covenants and agrees with the said Assignee that it will not execute any writing or do any act whatsoever conflicting with these presents, and that it will, at any time upon request, without further or additional consideration, but at the expense of the said Assignee, execute such additional assignments and other writings and do such additional acts as said Assignee may deem necessary or desirable to perfect the Assignee's enjoyment of this grant, and render all necessary assistance in making application for and obtaining original, continuations, continuations-in-part, continuing prosecutions, divisionals, renewals, reissues, reexamined or extended design registrations and Letters Patent of the OHIM, United States, or of any and all foreign countries, on said Design and Patent Rights, and execute confirmatory assignments or acknowledgments of this assignment as necessary for full enjoyment of the Design and Patent Rights and for recording in foreign patent offices, and in enforcing any rights or choses in action accruing as a result of such Design and Patent Rights, by giving testimony in any proceedings or transactions involving such Design and Patent Rights, and by executing preliminary statements and other affidavits, it being understood that the foregoing covenant and agreement shall bind, and inure to the benefit of, the assigns and legal representatives of both parties;

UPON SAID CONSIDERATION, Assignor represents and warrants that Assignor has the right, title, and authority to execute this Assignment and to convey any and all right, title, and interest in the Design and Patent Rights, and that Assignor has not conveyed nor will convey hereafter all or part of the Design and Patent Rights to a third party;

ASSIGNOR HEREBY AUTHORIZES said Assignee, its successors, and assigns, or anyone it may properly designate, to apply for design registrations and Letters Patent in the OHIM, United States, and any and all foreign countries and regions, in its own name if desired, and additionally to claim priority to the filing date of any design application or registration and otherwise take advantage of the provisions of any international conventions.

This Assignment may be executed in two or more counterparts and by facsimile, all of which shall be deemed an original, but all of which together shall constitute one and the same instrument.

The effective date of the Assignment is 12 December 2012.

Date: DEC 12, 2012

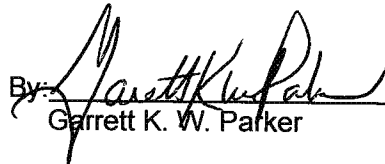
By:   
Garrett K. W. Parker

**ACCEPTANCE OF ASSIGNMENT**

The Assignee hereby acknowledges and accepts the foregoing assignment of rights by Assignor.

IN TESTIMONY WHEREOF, the Assignee, by its undersigned officer, confirms its acceptance of the Assignment as of the effective date of 12 December 2012.

SAMSONITE LLC

Date: DECEMBER 26, 2012

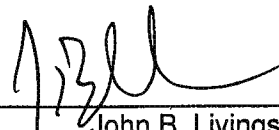
By:   
Name: John B. Livingston  
Title: Vice President and General Counsel

## REQUEST FOR DESIGN PATENT TO BE FILED

1. **Product Line Name:** \_\_\_\_\_ AT ball wheel \_\_\_\_\_

2. **Type of Product to be Protected (example: upright, duffel, spinner):** REDACTED

3. **List of All Inventors**

(Those who conceived of design, not just executed it). For Each Inventor, please provide:

Full legal name \_\_\_\_\_ Garrett K W Parker \_\_\_\_\_

Country of Citizenship \_\_\_\_\_ USA \_\_\_\_\_

Residential Address \_\_\_\_\_ 159 Bayview Ave \_\_\_\_\_ Berkley MA 02779

Employer \_\_\_\_\_ Samsonite \_\_\_\_\_

4. **Pictures (computer renderings, photographs, or line drawings):**

Please ensure that pictures of each of the following are attached:

- |                              |                                 |
|------------------------------|---------------------------------|
| _____ Front perspective view | _____ Right side elevation view |
| _____ Rear perspective view  | _____ Left side elevation view  |
| _____ Front elevation view   | _____ Top plan view             |
| _____ Rear elevation view    | _____ Bottom plan view          |

5. **Pictures must be taken as follows:**

- \_\_\_\_\_ Sharp focus
- \_\_\_\_\_ Dimensions consistent (example, shot from same distance and same focal length for each view)
- \_\_\_\_\_ Zipper pulls shown in same position for each view
- \_\_\_\_\_ Handle in retracted position for each view
- \_\_\_\_\_ All logos covered in all views
- \_\_\_\_\_ Wheels facing same direction for each view

6. **Public Disclosure Information**

Earliest publication or marketing date(s) \_\_\_\_\_

Earliest date(s) product design has been or will be discussed, demonstrated, or sold outside of Samsonite  
\_\_\_\_\_

Is there a confidentiality agreement in place? \_\_\_\_\_

7. **Country Where Design was**

Created \_\_\_\_\_ REDACTED \_\_\_\_\_

**8. Countries Where Application should be Filed (should include where sold and manufactured)**

---

*Remember, your work for Samsonite is Confidential Information. Please handle it appropriately.*

REDACTED

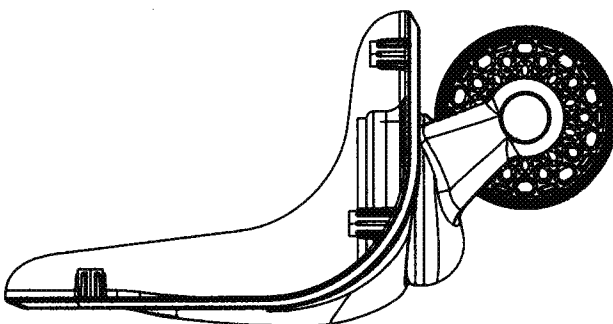
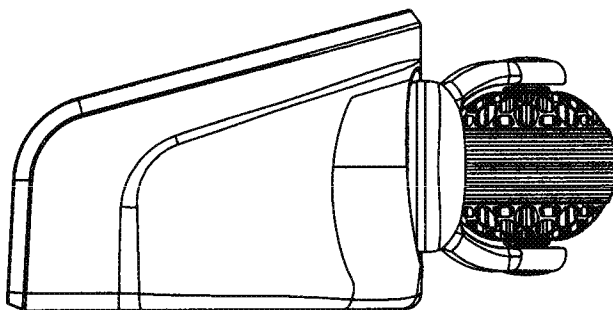
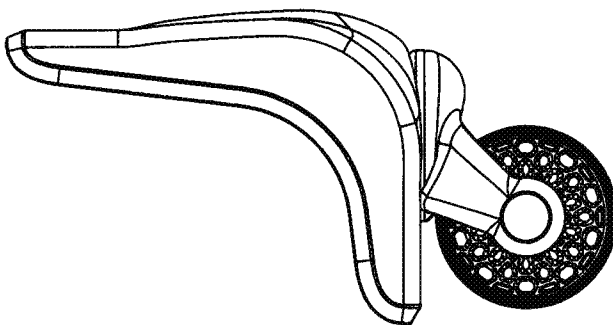
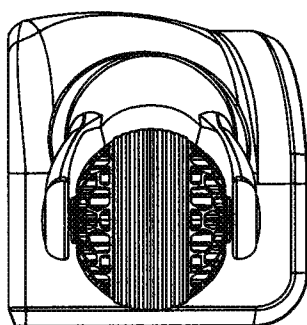
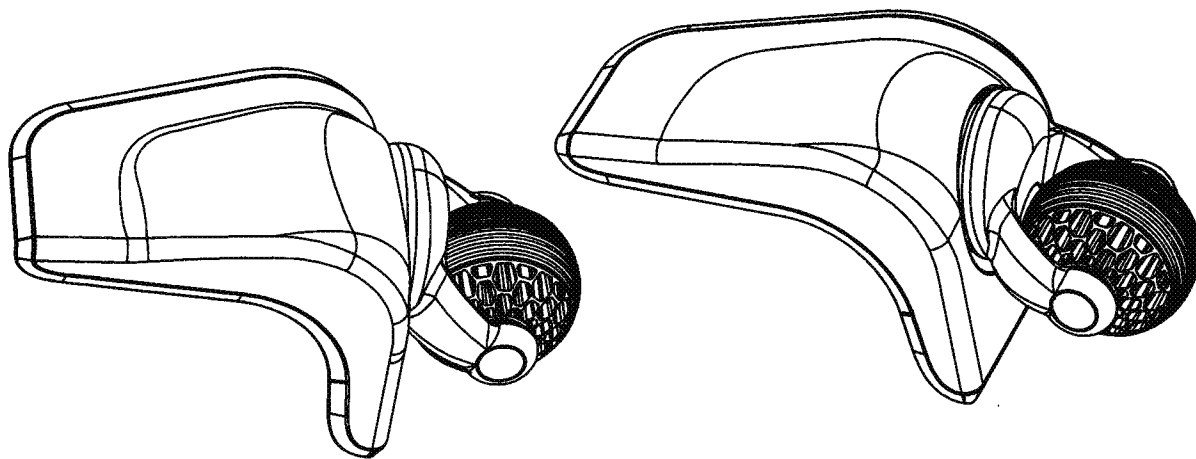



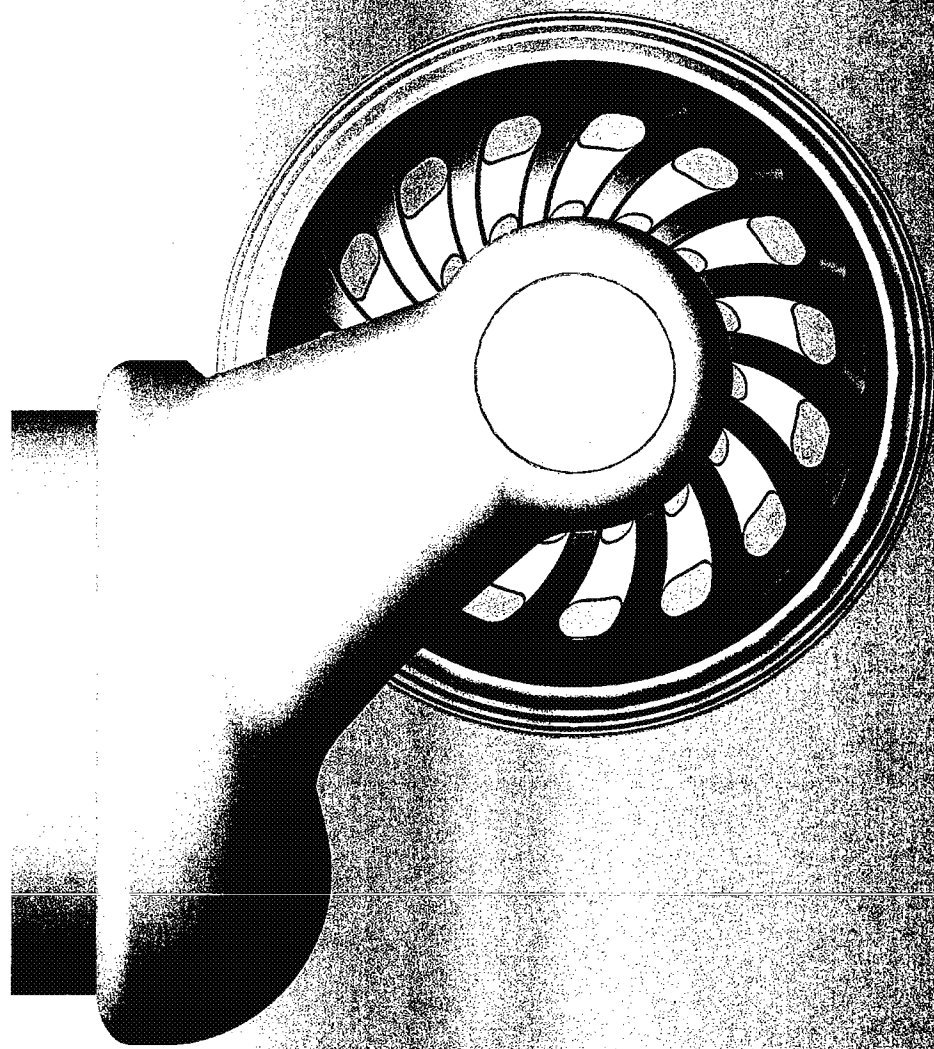

PATENT  
REEL: 035253 FRAME: 0010

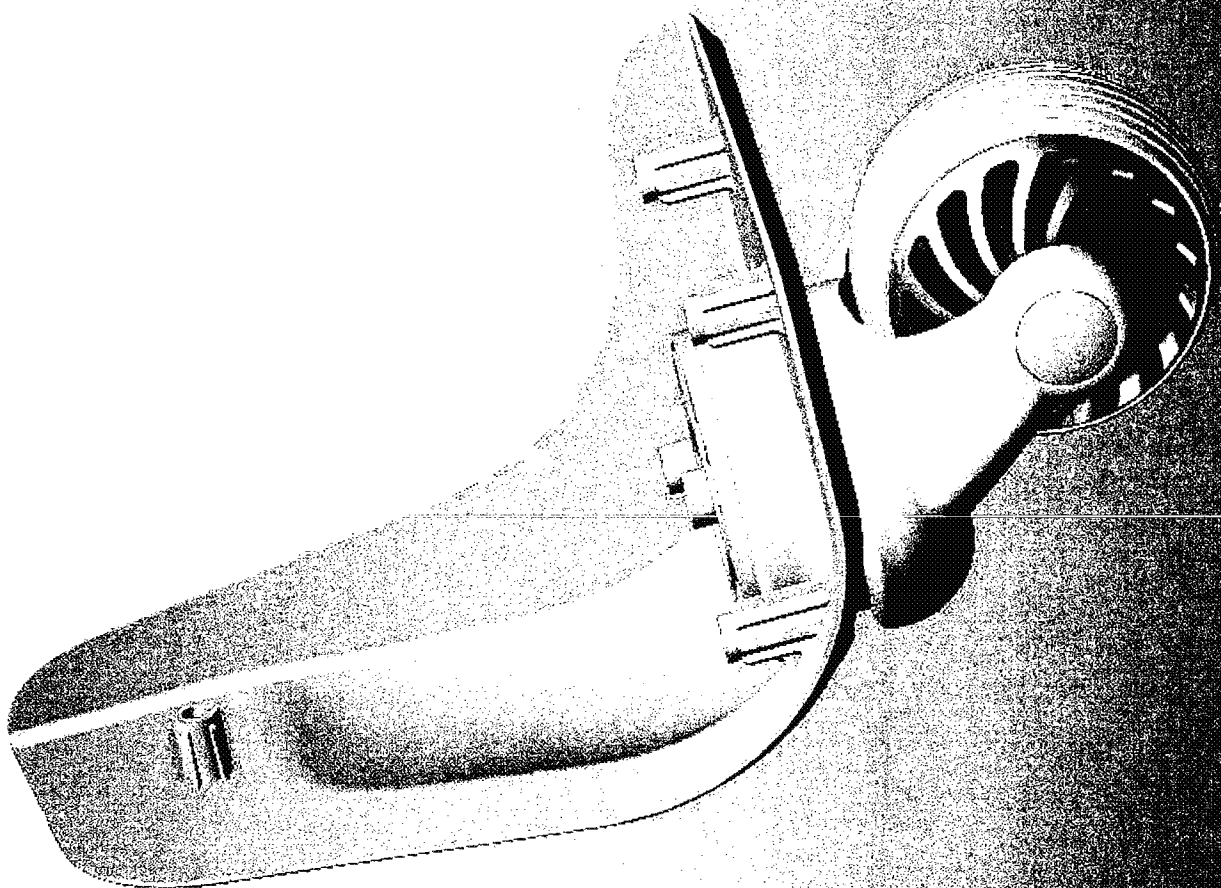

PATENT  
REEL: 035253 FRAME: 0510

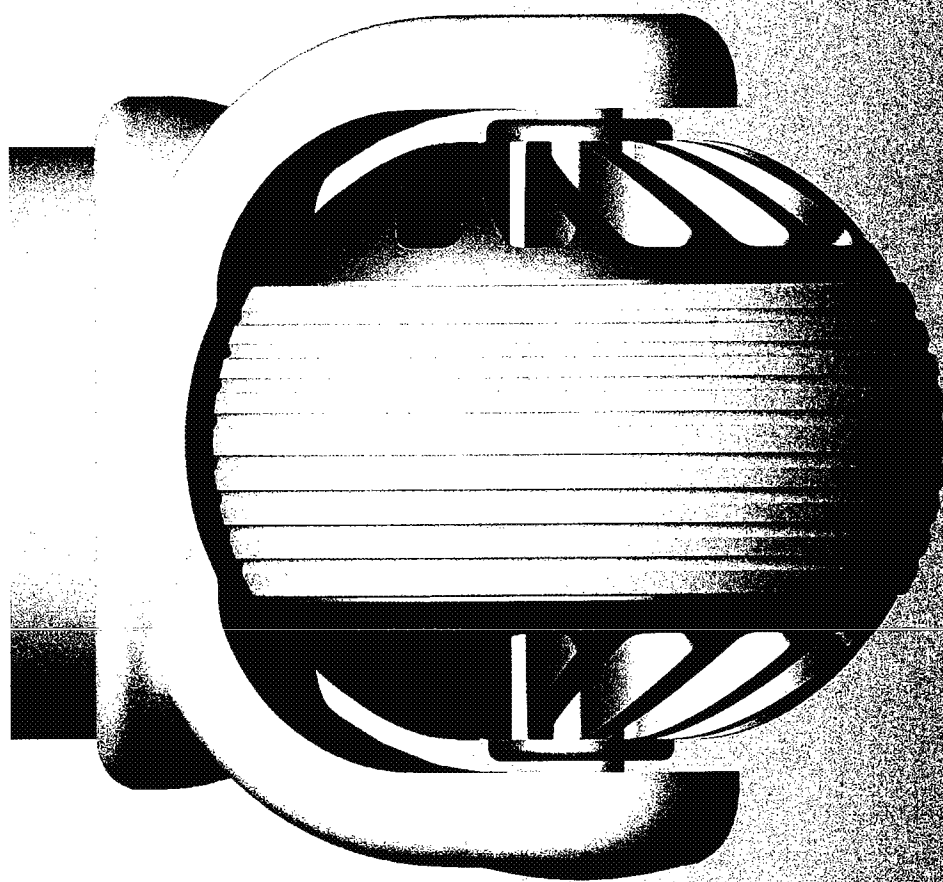

PATENT  
REEL: 035253 FRAME: 0317

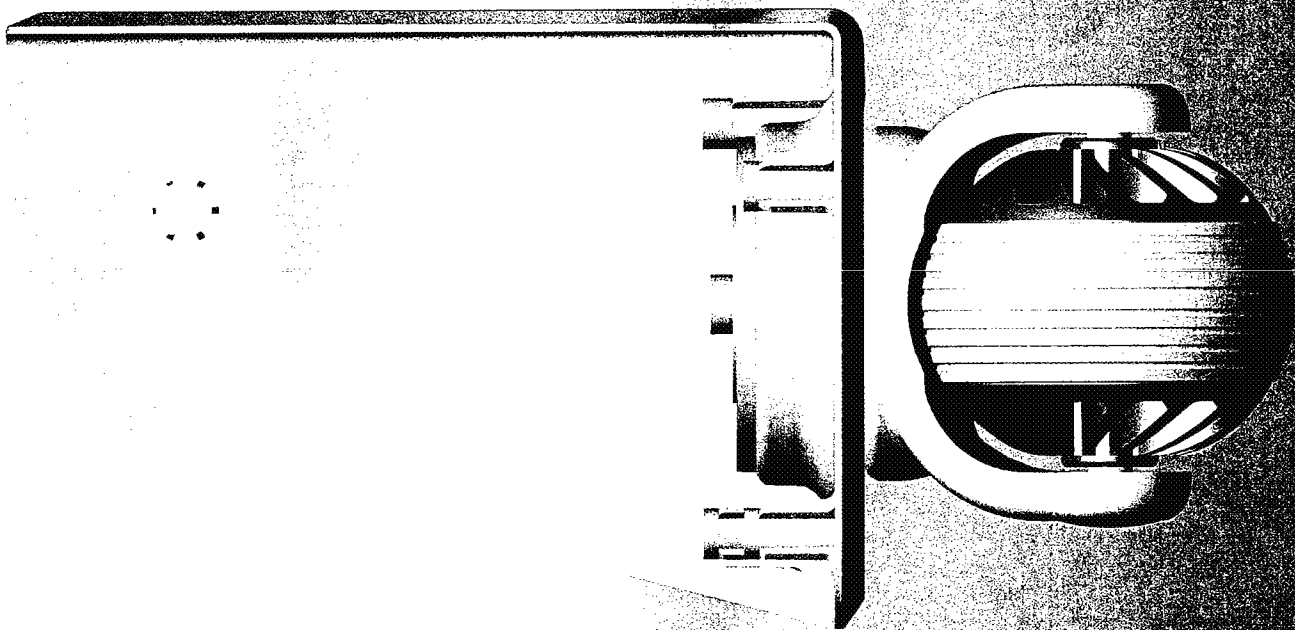

PATENT  
REEL: 035253 FRAME: 0516

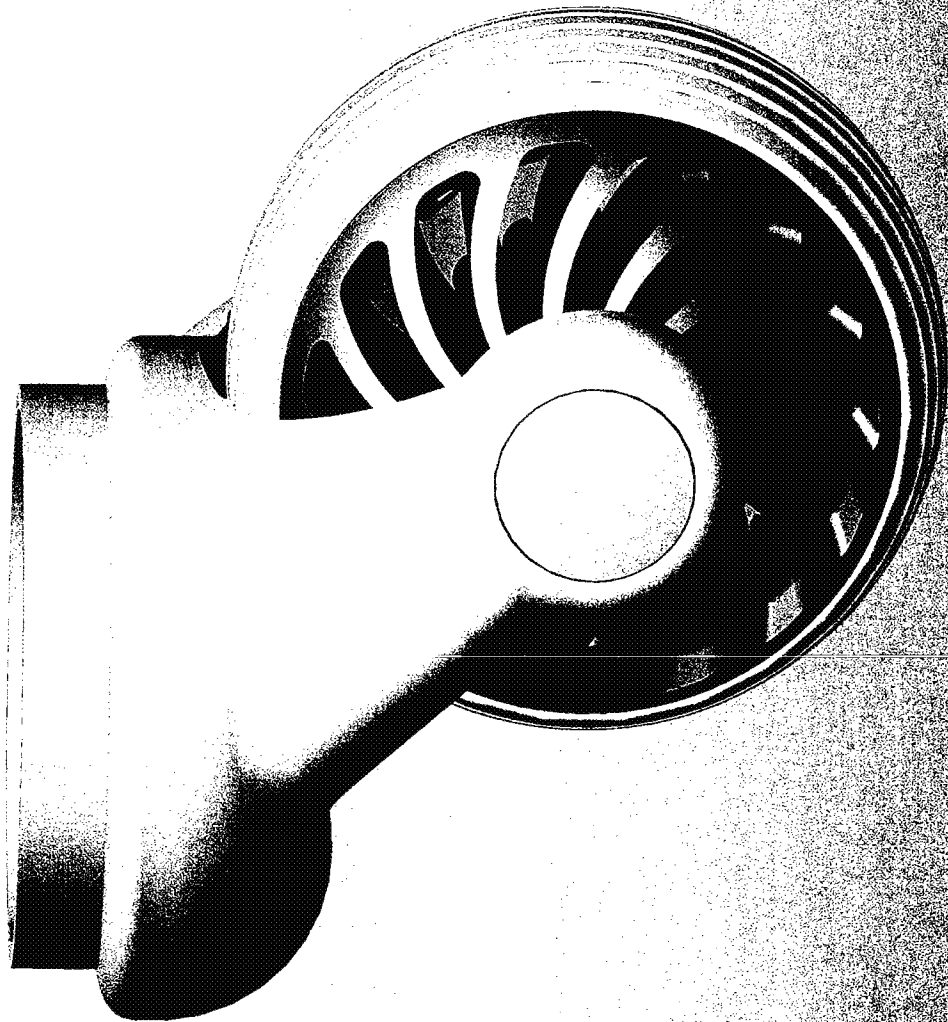

PATENT  
REEL: 035253 FRAME: 0319

