

PATENT ASSIGNMENT COVER SHEET

Electronic Version v1.1
 Stylesheet Version v1.2

EPAS ID: PAT4813307

SUBMISSION TYPE:	NEW ASSIGNMENT
NATURE OF CONVEYANCE:	ASSIGNMENT
CONVEYING PARTY DATA	
Name	Execution Date
LOGAN COMPLETION SYSTEMS, INC.	02/05/2018
RECEIVING PARTY DATA	
Name:	WELLFIRST TECHNOLOGIES, INC.
Street Address:	15815 WAVERLY DRIVE
City:	HOUSTON
State/Country:	TEXAS
Postal Code:	77032
PROPERTY NUMBERS Total: 2	
Property Type	Number
Patent Number:	9291034
Patent Number:	8727010
CORRESPONDENCE DATA	
Fax Number:	(512)391-6177
<i>Correspondence will be sent to the e-mail address first; if that is unsuccessful, it will be sent using a fax number, if provided; if that is unsuccessful, it will be sent via US Mail.</i>	
Phone:	5123916177
Email:	jray@munsch.com
Correspondent Name:	JAMES RAY
Address Line 1:	303 COLORADO STREET
Address Line 2:	SUITE 2600
Address Line 4:	AUSTIN, TEXAS 78701
ATTORNEY DOCKET NUMBER:	7449.8
NAME OF SUBMITTER:	JAMES RAY
SIGNATURE:	/james ray/
DATE SIGNED:	02/07/2018
This document serves as an Oath/Declaration (37 CFR 1.63).	
Total Attachments: 15	
source=IP Assignment Agreement#page1.tif	
source=IP Assignment Agreement#page2.tif	
source=IP Assignment Agreement#page3.tif	

source=IP Assignment Agreement#page4.tif
source=IP Assignment Agreement#page5.tif
source=IP Assignment Agreement#page6.tif
source=IP Assignment Agreement#page7.tif
source=IP Assignment Agreement#page8.tif
source=IP Assignment Agreement#page9.tif
source=IP Assignment Agreement#page10.tif
source=IP Assignment Agreement#page11.tif
source=IP Assignment Agreement#page12.tif
source=IP Assignment Agreement#page13.tif
source=IP Assignment Agreement#page14.tif
source=IP Assignment Agreement#page15.tif

ASSIGNMENT AGREEMENT

WHEREAS, Assignors, Logan Completion Systems, Inc., an entity formed under the laws of Alberta ("LCS" or "Assignor") is the Owner of Record of the inventions disclosed in the patents or patent applications ("Patents") and trademarks or trademark applications ("Marks") (the "Patents" and "Marks" are collectively referred to as the "Intellectual Property") listed in the attached Exhibit A, hereinafter called the "Intellectual Property", incorporated herein and made a part hereof.

WHEREAS, Assignor and Wellfirst Technologies, Inc., a Texas corporation ("Assignee"), entered into that certain Asset Purchase Agreement dated as of July 20, 2017, under which Assignor sold transferred and assigned to Assignee, all right, title and interest in and to the Intellectual Property (the "Purchase Agreement").

NOW THEREFORE, for the good and valuable consideration paid to Assignor by Assignee, the receipt and sufficiency of which is hereby acknowledged, and to evidence certain transfers and assignments made in the Purchase Agreement, ASSIGNOR HEREBY ASSIGNS TO ASSIGNEE:

1. The entire right, title and interest in the Patents disclosed therein and in all applications claiming the benefit thereof or priority thereto and in all divisions, continuations and continuations-in-part of said applications, or reissues or extensions of Letters Patent or patents issuing therefrom or granted thereon, and in all corresponding applications which may be filed in countries foreign to the United States, and in all patents issuing thereon in the United States and foreign countries.
2. All of the right, title and interest, whether statutory or at common law, in and to the Marks, together with the entire business symbolized by the Marks, the goodwill of the business symbolized by the Marks, the right to sue for past, present and future infringement, dilution, misappropriation, violation, or breach thereof, and the right to recover, collect and own any monetary or other damages, and to obtain injunctive relief, as a result thereof.
3. The right to file foreign patent applications on said inventions disclosed in the Patents in its own name, wherever such right may be legally exercised, including the right to claim the benefits of the International Convention for such applications.
4. All claims for damages and all of the remedies arising out of any infringement of any Patents or from any inventions otherwise assigned herein which may have accrued prior to the date of this assignment or may accrue, including, but not limited to, the right to sue for and collect and retain damages for past infringements of the Patents or on any of the inventions otherwise assigned herein.
5. All right, title and interest in and to any and all other intellectual property rights owned by Assignor in all documentation, source code or other materials, if any, implementing the inventions set forth in the Intellectual Property.
6. Assignor hereby authorizes and requests the United States Commissioner of Patents and Trademarks, and such Patent and Trademark Office officials in foreign countries as are duly authorized by their laws, to issue any and all patents or trademarks on any patent or trademark applications related to the Intellectual Property or to any other invention otherwise assigned herein to the Assignee as the owner of the entire interest, for the sole use and benefit of the said Assignee, its successors, assigns and legal representatives.

7. Assignor hereby agrees to sign all lawful papers and to perform all other lawful acts which the Assignee may request of Assignor to make this Assignment fully effective, including, by way of example but not of limitation, the following:
 - a. Prompt execution of all original, divisional, substitute, reissue, and other United States and foreign patent applications on said inventions, and all lawful documents requested by the Assignee to further the prosecution of any of such patent applications.
 - b. Cooperation to the best of Assignor's ability in the execution of all lawful documents, the production of evidence, nullification, reissue, extension, or infringement proceedings involving said inventions.

[SIGNATURE PAGE FOLLOWS]

This assignment and agreement shall be binding upon Assignor's heirs and legal representatives dated this 5th day of February, 2018.

ASSIGNEE:

Wellfirst Technologies, Inc.

Printed Name: _____

Title: _____

ASSIGNOR:

Logan Completion Systems, Inc.



Printed Name: John Grigg

Title: Director

Exhibit A Transferred Assets

Booked	Attorney/Ref	Patent/Trademark Title	City	App Date	App No.	Granting Date	Patent/Trademark # No.	Status	Owner	Next due date	Remarks
136943-2001	LCSB-P0004CA	PATENT METHOD AND APPARATUS FOR USE IN SELECTIVELY FRACING A WELL	CA	08/14/08	2811778			Abandoned	Logan Completion Systems Inc.		
136943-0887	LCSB-P0004CA-D1	PATENT METHOD AND APPARATUS FOR USE IN SELECTIVELY FRACING A WELL	CA	08/14/08	2802871			Abandoned	Logan Completion Systems Inc.		
136943-2003	LCSB-P0005WO-CA-D1	PATENT SELECTIVE FRACTURING TOOL	CA	09/08/09	2737881	08/18/13	2737881	Issued	Logan Completion Systems Inc.	04/26/14	Apprises past due, can be refiled before April 16, 2016
136943-2005	LCSB-P0003WO-CA-D1	PATENT SELECTIVE FRACTURING TOOL	CA	07/27/12	2784589	10/25/16	2784589	Issued	Logan Completion Systems Inc.	04/26/14	Apprises past due, can be refiled before April 16, 2016
136943-1603	LCSB-P0008WO	PATENT SELECTIVE FRACTURING TOOL	US	02/16/12	12286436	08/22/19	9,231,034	Issued	Logan Completion Systems Inc.		
136943-1604	LCSB-P0008WO-US-D1	PATENT SELECTIVE FRACTURING TOOL	US	07/25/12	13,657,433	05/20/14	8,737,510	Issued	Logan Completion Systems Inc.		
136943-7000	LCSB-M0001CA	TRADEMARK MULTIFLEX	CA	06/11/05	1395229	12/19/09	TMA/155477	Registered	Logan Completion Systems Inc.	12/19/24	Renewal
136943-8001	LCSB-M0003US	TRADEMARK MULTIFLEX	US	08/11/11	85318728			Pending	Logan Completion Systems Inc.	na	avg approval of Statement of Use
136943-3002	LCSB-M0003US	TRADEMARK MULTIFLEX	US	08/11/11	85318436			Pending	Logan Completion Systems Inc.	na	avg approval of Statement of Use

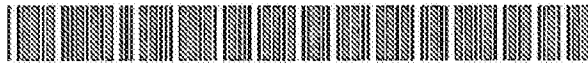

US008727010B2

(12) **United States Patent**
Turner et al.

(10) **Patent No.:** **US 8,727,010 B2**
(45) **Date of Patent:** **May 20, 2014**

(54) **SELECTIVE FRACTURING TOOL**
(75) **Inventors:** **Don Turner, Lloydminster (CA); Sean Campbell, Airdrie (CA); Grant George, Kelowna (CA)**
(73) **Assignee:** **Logan Completion Systems Inc., Calgary, Alberta (CA)**
(*) **Notice:** Subject to any disclaimer, the term of this patent is extended or adjusted under 35 U.S.C. 154(b) by 0 days.

(21) **Appl. No.:** **13/557,438**

(22) **Filed:** **Jul. 25, 2012**
(Under 37 CFR 1.47)

(65) **Prior Publication Data**
US 2012/0285687 A1 Nov. 15, 2012

Related U.S. Application Data
(63) Continuation of application No. 13/266,498, filed as application No. PCT/CA2010/000620 on Apr. 26, 2010.

(60) Provisional application No. 61/172,915, filed on Apr. 27, 2009.

(51) **Int. Cl.**
E21B 34/14 (2006.01)

(52) **U.S. Cl.**
USPC 166/332.4; 166/373; 166/306; 166/177.5; 166/334.4

(58) **Field of Classification Search**
CPC E21B 23/04; E21B 34/08; E21B 34/10; E21B 34/105; E21B 34/14; E21B 43/25; E21B 43/26; E21B 2034/002
USPC 166/373, 381, 383, 386, 318, 332.1, 166/332.4

See application file for complete search history.

(56) **References Cited**

U.S. PATENT DOCUMENTS

3,244,234 A 4/1966 Flickinger
4,512,406 A 4/1985 Vann et al.

(Continued)

FOREIGN PATENT DOCUMENTS

CA 2412072 A1 5/2003
CA 2471599 A1 7/2003

(Continued)

OTHER PUBLICATIONS

International Search Report and Written Opinion received in Patent Cooperation Treaty Application No. PCT/CA2010/000620, dated Sep. 20, 2010, 8 pages.

(Continued)

Primary Examiner — Jennifer H Gny

Assistant Examiner — Elizabeth Gitlin

(74) *Attorney, Agent, or Firm* — Marc A. Hubbard; Hubbard Law PLLC

(57) **ABSTRACT**

A tool for selectively treating a wellbore with fluid that includes a tubing string having a sidewall defining an inner bore, the sidewall comprising a flow area having at least one fluid flow port that permits fluid flow through the sidewall. Fluid is prevented from flowing through the flow area when a closure is in a closed position. When in the open position, fluid flows through the flow area. An axial seal is connected to the closure to selectively close the inner bore against fluid pressure to apply the predetermined opening force to move the closure to the open position. A releasable connector connects the axial seal to the closure and a retrieval tool attachment releases the axial seal from the closure upon application of a predetermined release force by a retrieval tool.

8 Claims, 7 Drawing Sheets

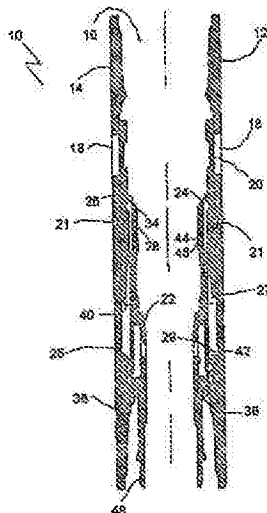

(56)

References Cited

U.S. PATENT DOCUMENTS

5,048,611 A 9/1991 Cochran
 5,168,931 A 12/1992 Caskey et al.
 5,358,048 A 10/1994 Brooks
 5,443,124 A 8/1995 Wood et al.
 6,186,236 B1 2/2001 Cox
 6,253,856 B1 7/2001 Ingram et al.
 6,488,082 B2 12/2002 Echols et al.
 6,695,057 B2 3/2004 Ingram et al.
 6,776,238 B2 8/2004 Dusterhoft et al.
 6,782,948 B2 9/2004 Echols et al.
 6,907,936 B2 6/2005 Fehr et al.
 7,021,384 B2 4/2006 Themig
 7,096,954 B2 8/2006 Weng et al.
 7,108,067 B2 9/2006 Themig et al.
 7,114,558 B2 10/2006 Hoffman et al.
 7,134,505 B2 11/2006 Fehr et al.
 7,267,172 B2 9/2007 Hofman
 7,350,582 B2 4/2008 McKeschnie et al.
 7,353,878 B2 4/2008 Themig
 7,431,091 B2 10/2008 Themig et al.
 7,543,634 B2 6/2009 Fehr et al.
 7,748,460 B2 7/2010 Themig et al.
 7,762,313 B2 7/2010 Themig et al.
 7,861,774 B2 1/2011 Fehr et al.
 7,992,645 B2 8/2011 Themig
 2003/0127227 A1 7/2003 Fehr et al.
 2004/0020652 A1 2/2004 Campbell et al.
 2006/0000620 A1 1/2006 Hamilton
 2006/0124310 A1 6/2006 Lopez de Cardenas et al.
 2007/0204995 A1 9/2007 Hoffman et al.
 2007/0240883 A1* 10/2007 Telfer 166/375
 2007/0272413 A1 11/2007 Rytlewski et al.
 2008/0135248 A1 6/2008 Talley et al.
 2009/0008083 A1 1/2009 Themig et al.
 2009/0071644 A1 3/2009 Themig
 2009/0095471 A1 4/2009 Guignard et al.

2010/0263873 A1 10/2010 Turner et al.
 2011/0067890 A1 3/2011 Themig
 2011/0100643 A1 5/2011 Themig et al.
 2011/0127847 A1 6/2011 Themig et al.
 2011/0278017 A1 11/2011 Themig et al.

FOREIGN PATENT DOCUMENTS

CA 2437635 A1 2/2004
 CA 2472824 A1 12/2005
 CA 2628368 A1 8/2009
 CA 2637519 A1 10/2009
 CA 2719561 A1 11/2009
 CA 2726200 A1 12/2009
 CA 2726207 A1 12/2009
 CA 2641778 4/2010
 CA 2682621 4/2010
 CA 2731161 11/2010
 WO WO 03/056131 A1 7/2003
 WO WO 2010/124371 11/2010
 WO WO 2011/057416 A1 5/2011
 WO WO 2011/072367 A1 6/2011
 WO WO 2011/079391 A1 7/2011
 WO WO 2011/130846 A1 10/2011

OTHER PUBLICATIONS

"Multi-Stage System Completion with Packers," Xtreme Oil Tools, Strata-Pak System Information, at least as early as Oct. 2009, 3 pages.
 Thomson, D.W., et al., "Design and Installation of a Cost-Effective Completion System for Horizontal Chalk Wells Where Multiple Zones Require Acid Stimulation," SPE Drilling & Completion, Sep. 1998, pp. 151-156.
 Canadian Office Action received in Canadian Patent Application No. 2,731,161, dated Dec. 13, 2011, 3 pages.
 Canadian Office Action received in Canadian Patent Application No. 2,731,161, dated Jul. 11, 2011, 3 pages.

* cited by examiner

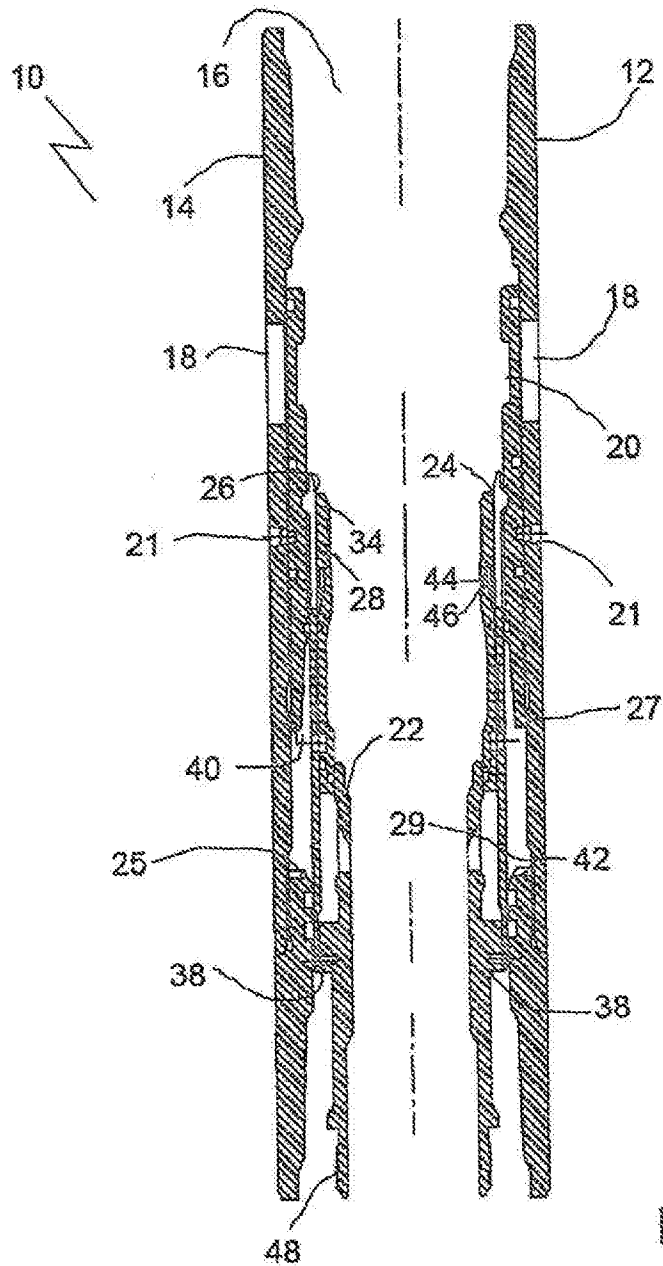

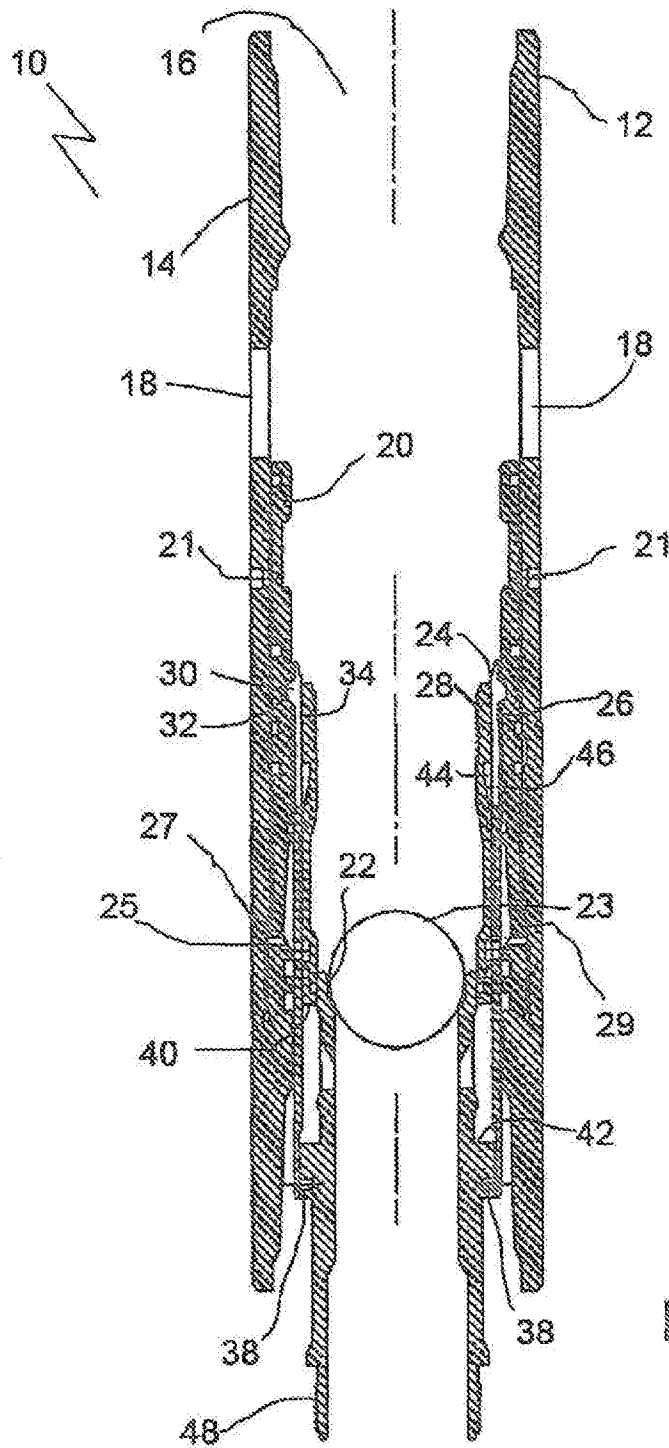
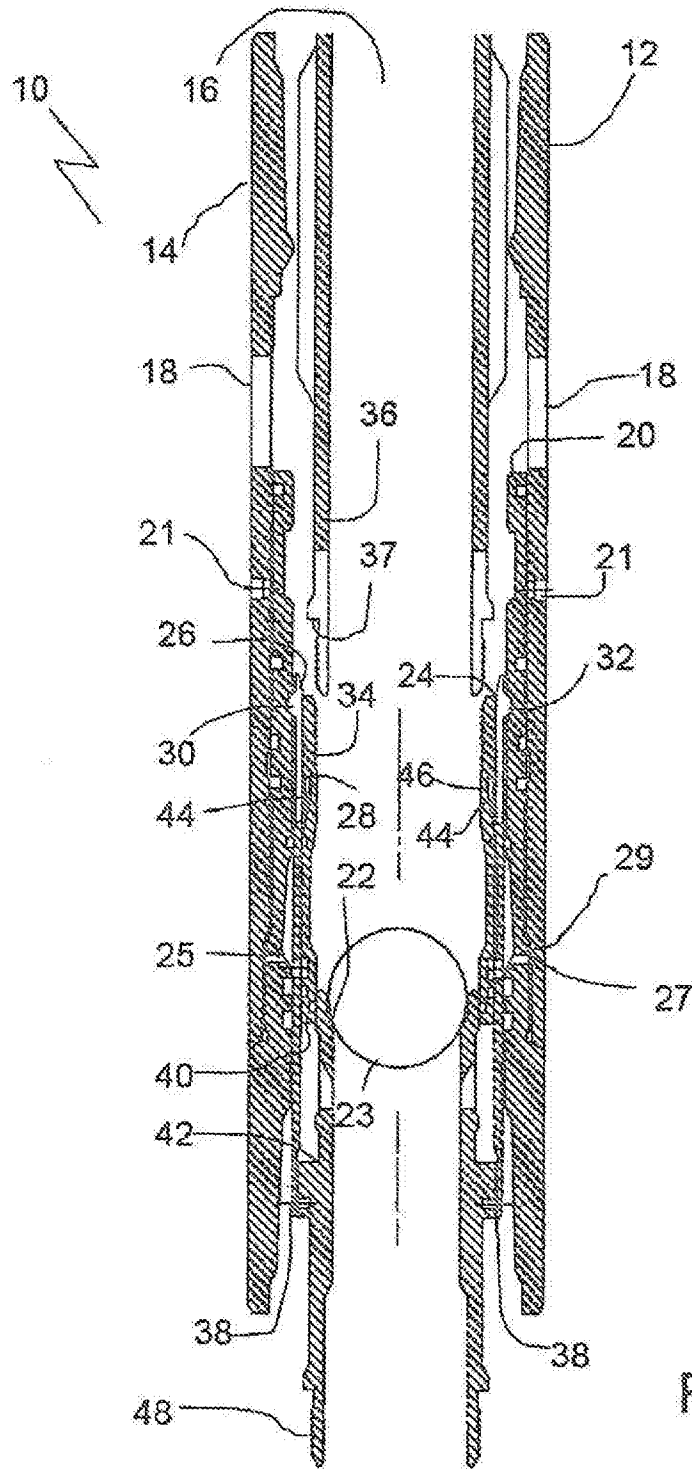

FIG. 2



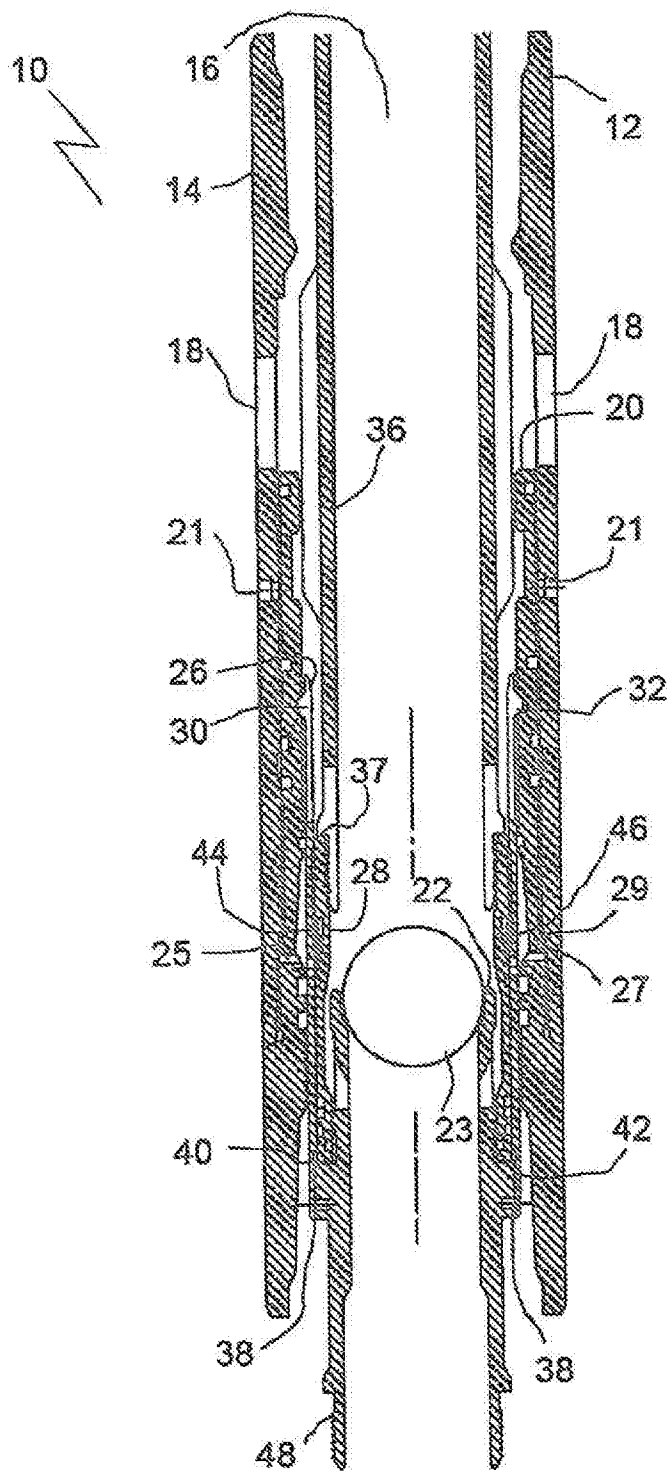

FIG. 4

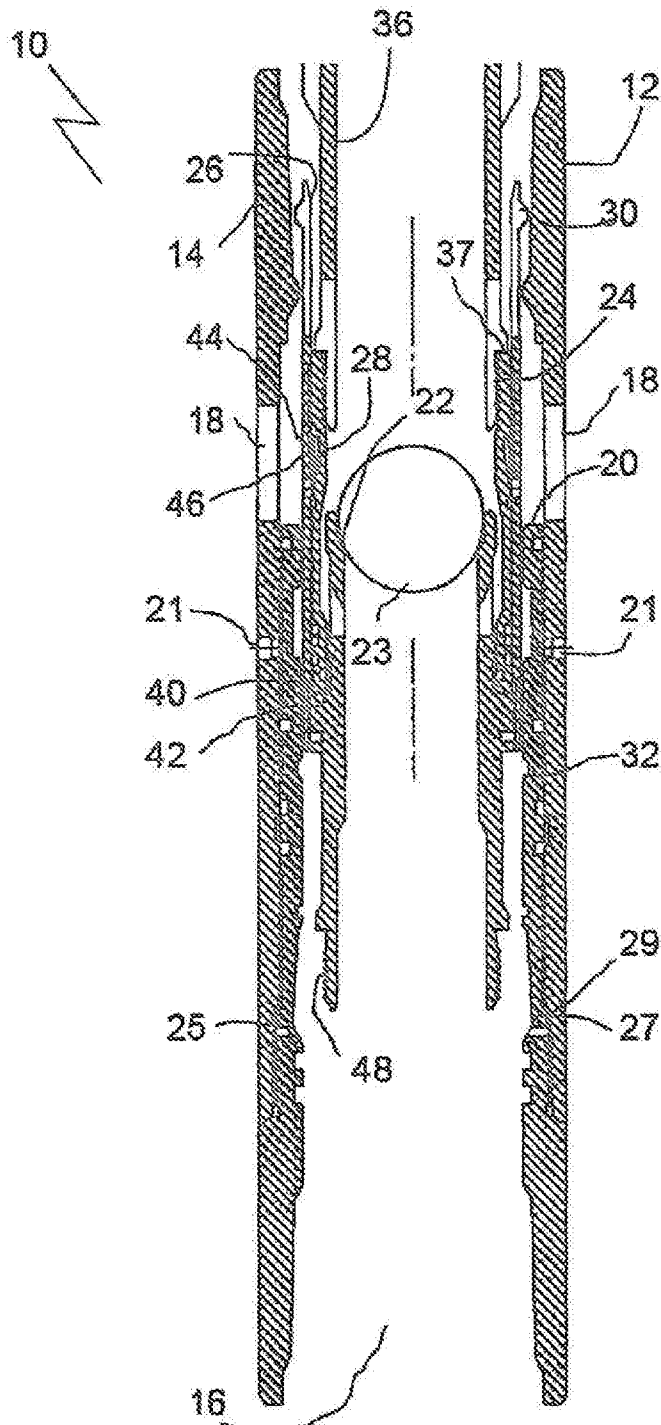

FIG. 5

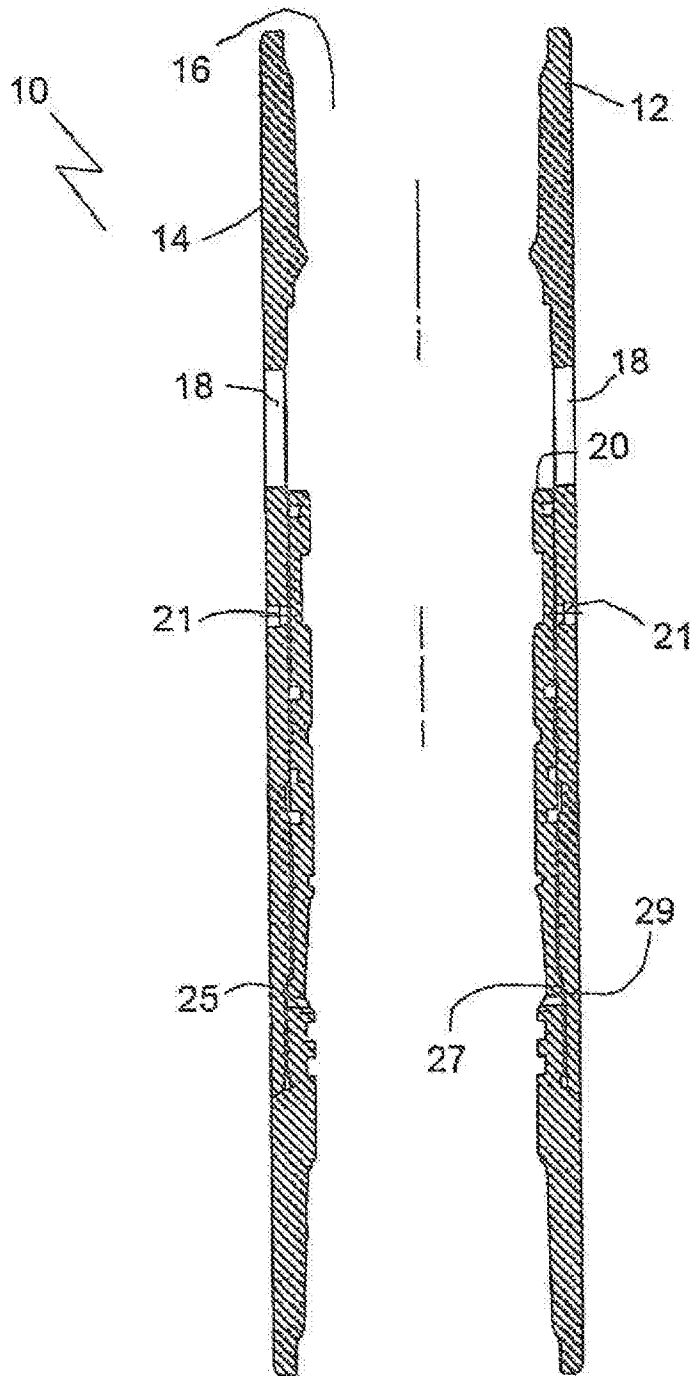

FIG. 6

SELECTIVE FRACTURING TOOL

This application is a continuation of U.S. application Ser. No. 13/266,498 entitled "Selective Fracturing Tool," filed Mar. 16, 2012, which is a national stage filing of PCT application serial number PCT/CA10/00620, filed Apr. 26, 2010, which claims the benefit of U.S. provisional application Ser. No. 61/172,915, filed Apr. 27, 2009.

FIELD

This relates to a tool for selectively fracturing a formation containing hydrocarbons.

BACKGROUND

U.S. Pat. No. 7,108,067 (Thermy et al.) entitled "Method and apparatus for wellbore fluid treatment" describes a tool in which sleeves are shifted in order to open fracturing ports.

SUMMARY

There is provided a tool for selectively treating a wellbore with fluid that includes a tubing string having a sidewall defining an inner bore, the sidewall comprising a flow area having at least one fluid flow port that permits fluid flow through the sidewall. A closure is movably positioned over the flow area and prevents fluid flow through the flow area in a closed position and allows fluid flow in an open position. An axial seal is connected to the closure to selectively close the inner bore against fluid pressure to apply the predetermined opening force to move the closure to the open position. A releasable connector connects the axial seal to the closure and a retrieval tool attachment releases the axial seal from the closure upon application of a predetermined release force by a retrieval tool.

BRIEF DESCRIPTION OF THE DRAWINGS

These and other features will become more apparent from the following description in which reference is made to the appended drawings, the drawings are for the purpose of illustration only and are not intended to be in any way limiting, wherein:

FIG. 1 is a side elevation view, in section, of the selective fracturing tool.

FIG. 2 is a side elevation view, in section, of the selective fracturing tool shown in FIG. 1 with flow ports in the open position.

FIG. 3 is a side elevation view, in section, of the selective fracturing tool shown in FIG. 1 with a removal tool inserted.

FIG. 4 is a side elevation view, in section, of the selective fracturing tool shown in FIG. 1 with the removal tool locked in position.

FIG. 5 is a side elevation view, in section, of the selective fracturing tool shown in FIG. 1 with the removal tool removing the ball seat.

FIG. 6 is a side elevation view, in section, of the selective fracturing tool shown in FIG. 1 with full bore access.

FIG. 7 is a side elevation view of a tubing string containing a series of selective fracturing tools.

DETAILED DESCRIPTION

A selective fracturing tool, generally identified by reference numeral 10, will now be described with reference to FIG. 1 through 7.

Referring to FIG. 1, tool 10 has a tubing string 12 having a sidewall 14, an inner bore 16 and flow areas made up of one or more flow ports 18 that permit fluid flow through sidewall 14. A closure 20 is positioned over flow ports 18. As shown, closure 20 is an annular sleeve that shifts axially within sidewall 14, and is connected to sidewall 14 by shear pins 21. Closure 20 is initially in a closed position as shown in FIG. 1 to prevent fluid flow through flow ports 18, and may be moved to an open position, shown in FIG. 2 and described below, to allow fluid to flow through flow ports 18. As shown in FIG. 4, tubing string 12 includes multiple flow areas 18 that are axially spaced, each having a closure 20 and the other components described below. An axial seal 22, such as a ball seat as depicted, is connected to closure 20. Axial seal 22 is initially in an open position, but may be closed to seal inner bore 16, such as by placing a ball 23 in ball seat 22, which allows pressure to be applied to closure 20 to move closure 20 to the open position. Axial seal 22 is attached to closure 20 via a releasable connector 24 that is released by a retrieval tool as discussed below. Referring to FIG. 2, in the depicted embodiment, a ball 23 is pumped down tubing string 12 and engages ball seat 22. Fluid pressure is then applied by increasing the hydrostatic pressure in inner bore 16. This causes closure 20 to shear pins 21 and shift axially to open flow ports 18. It will be understood that closure 20 may also open flow ports 18 by, for example, being rotated by the fluid pressure applied to ball seat 22. In addition, other means of releasing closure 20 may also be used. In the open position, closure 20 is stopped by a shoulder 25 on sidewall 14, and preferably has a latch end 27 that engages a latching profile 29 in sidewall 14 to prevent it from unintentionally returning to the closed position.

Preferably, when multiple closures 20 are selectively shifted, the diameter of downstream ball seats 22 are progressively smaller than the upstream ball seats 22, such that a smaller ball may be pumped down through other, larger, ball seats 22 to the end of tubing string 12 to open that closure. The next ball will be larger to engage the next ball seat 22, but still small enough to pass through the upstream ball seats 22, and so forth so that all closures 20 are opened.

Referring to FIG. 3, once opened, axial seal 22 can then be removed to provide "full bore" access to tubing string 12 by releasing releasable connector 24. In the depicted embodiment, releasable connector 24 is made up of a diameter reducing sleeve 26 and a locking sleeve 28. Sleeve 26 has an outer profile 30 that engages a corresponding profile 32 on closure 20. As shown, profiles 30 and 32 are sloped on both sleeve 26 and closure 20. This portion of sleeve 26 is a diameter reducing section. This may be done by providing a series of resilient fingers that, when an axial force is applied in either direction, bend inward to release sleeve 26 from closure 20. Preferably, the fingers are biased inward, such that once they are released, they do not catch on closure 20. The space between the resilient fingers may be filled with a compressible substance to properly seal sleeve 26. Axial seal 22 is attached, such as by pins 27, to the other end of diameter-reducing sleeve 26. Sleeve 28 is a locking sleeve that prevents diameter reducing sleeve 26 from being released from profile 32 on closure 20. Locking sleeve 28 has a retrieval tool attachment 34 at one end that engages a retrieval tool 36, and is connected by shear pins 38 to one of axial seal 22 or sleeve 26 at the other end.

Referring to FIG. 4, as shown, retrieval tool 36 engages retrieval tool attachment 34 using a ratchet design that allows it to be inserted in one direction, and afterward locks in place. Retrieval tool 36 has a shoulder 37 to prevent it from being inserted too far into locking sleeve 28. Shoulder 37 is then used to apply pushing forces to locking sleeve 28. When

retrieval tool 36 applies a sufficient force to release shear pins 38, locking sleeve 28 shifts downward and diameter reducing section is no longer locked in place. Locking sleeve 28 then becomes locked into this release position, as the downstream end 40 of locking sleeve 28 comes into contact with a shoulder 42 of axial seal 22, and dogs 44, which are mounted in a groove 46 locking sleeve 28 against a sloped outer surface, engage diameter reducing sleeve 26 by friction to prevent locking sleeve 28 from moving back to the locked position. This allows a pushing or pulling force to be applied by retrieval tool 36 at this point that will move axial seal 22 and sleeves 26 and 28 together to remove retrieval tool 36.

Referring to FIG. 7, a series of selective fracing tools 10 are deployed along a production tubing string 50 with packers 52, such as hydraulically set dual element open hole packers. The type of packer used will be selected based on the conditions and preferences of the user. Tubing string 50 is inserted into the casing 54 of a wellbore 56, such that tool 10 is aligned with the portion of the formation to be fraced.

When multiple fracing tools 10 are used as shown in FIG. 7, each axial seal 22 may be removed individually to obtain the full bore flow path shown in FIG. 6. In this approach, retrieval tool 36 is inserted once for each axial seal 22. Alternatively, more than one axial seal 22 may be removed in multiples. As shown, in FIG. 4, axial seal 22 has a downstream end 48 that has a similar connection as retrieval tool 36. Once an upstream axial seal 22 is released, it may be pushed to engage the next downstream axial seal 22, where downstream end 48 engages retrieval tool attachment 34 of the next axial seal 22. At this point, axial seal 22 can be considered part of the retrieval tool 36. The axial seals 22 can then be pulled out of tubular body 12 at the same time.

In this patent document, the word "comprising" is used in its non-limiting sense to mean that items following the word are included, but items not specifically mentioned are not excluded. A reference to an element by the indefinite article "a" does not exclude the possibility that more than one of the element is present, unless the context clearly requires that there be one and only one of the elements.

The following claims are to be understood to include what is specifically illustrated and described above, what is conceptually equivalent, and what can be obviously substituted. Those skilled in the art will appreciate that various adaptations and modifications of the described embodiments can be configured without departing from the scope of the claims. The illustrated embodiments have been set forth only as examples and should not be taken as limiting the invention. It is to be understood that, within the scope of the following claims, the invention may be practiced other than as specifically illustrated and described.

What is claimed is:

1. A tool for selectively treating a well with fluid, comprising:

- tubing having a sidewall defining an inner bore;
- a flow port defined through the sidewall for communicating fluid from the inner bore through the sidewall;
- a first closure within the tubing shiftable between a closed position for blocking communication of fluids through

the flow port, and an open position for permitting communication of fluid through the flow port;

- a first axial seal for selectively closing the inner bore to block all fluid flowing through the tool in a downstream direction, the first axial seal being connected to the first closure for applying, when closed, a force to move the closure to the open position;
- a first releasable connector for connecting the first axial seal to the first closure, and
- a downstream end located on the first axial seal specially adapted for connecting to a second axial seal of a second closure downstream from the first axial seal.

2. The tool of claim 1, wherein the second axial seal is connected with the second closure by a second releasable connector, wherein the downstream end of the first axial seal is configured for applying a force for releasing the second releasable connector once the first axial seal is released from the first closure and moved downstream for connection to the second axial seal.

3. The tool of claim 2, further comprising a retrieval tool for lowering through the inner bore and applying a force for releasing the first axial seal from the first closure.

4. The tool of any of claim 1, wherein the first and second axial seals are each comprised of a ball seat for receiving a pumped ball to close the inner bore.

5. The tool of claim 4, wherein the ball seat for the first axial seal has a larger diameter than the ball seat of the second axial seal.

6. A method of selectively treating a well bore with fluid, comprising:

- lowering into a well bore a tool, the tool comprising, tubing having an inner bore for communicating fluid under pressure and at least first and second flow ports disposed along its length, the second flow port being downstream from the first flow port,

- a first closure and a second closure for selectively opening, respectively, the first and second flow ports to the flow of fluid through the flow port independently of the other flow ports,

- a first axial seal connected to the first closure by a first releasable connector and a second axial seal connected to the second closure by a second releasable connector, and

- a downstream end for at least the first axial seal configured for connecting to the second axial seal;

- inserting a retrieval tool into the tubing to release the first releasable connector and to connect to the axial seal of the first flow port;

- moving the released axial seal of the first flow port toward the axial seal of the second flow port; and

- releasing the second axial seal from the second closure of the second flow port with the downstream end of the axial seal of the first flow port.

7. The method of claim 6, wherein the first and second axial seals are pushed toward the end of the well bore.

8. The method of claim 6, wherein the first and second axial seals are pulled together with the retrieval tool through the tubing toward the surface of the well.

* * * * *